

NH-Sicherungslastschaltleisten

NH strip-type fuse-switch-disconnectors

Maßzeichnungen/*Dimensions*

Typ/Type	Artikel-Nr./Article-No.	Seite/Page	Typ/Type	Artikel-Nr./Article-No.	Seite/Page
SL00-3X3/100/F	L5051001	SL-13	SL00-3X3/100/F/HA/W/...	L5351001	SL-29
SL00-3X3/100/F70	L5057002	SL-13	SL00-3X3/100/F70/HA/W/...	L5357002	SL-29
SL00-3X3/100/KU00	L5056003	SL-13	SL00-3X3/100/KU00/HA/W/...	L5356003	SL-29
SL00-3X3/100/KM00	L5059004	SL-13	-	-	-

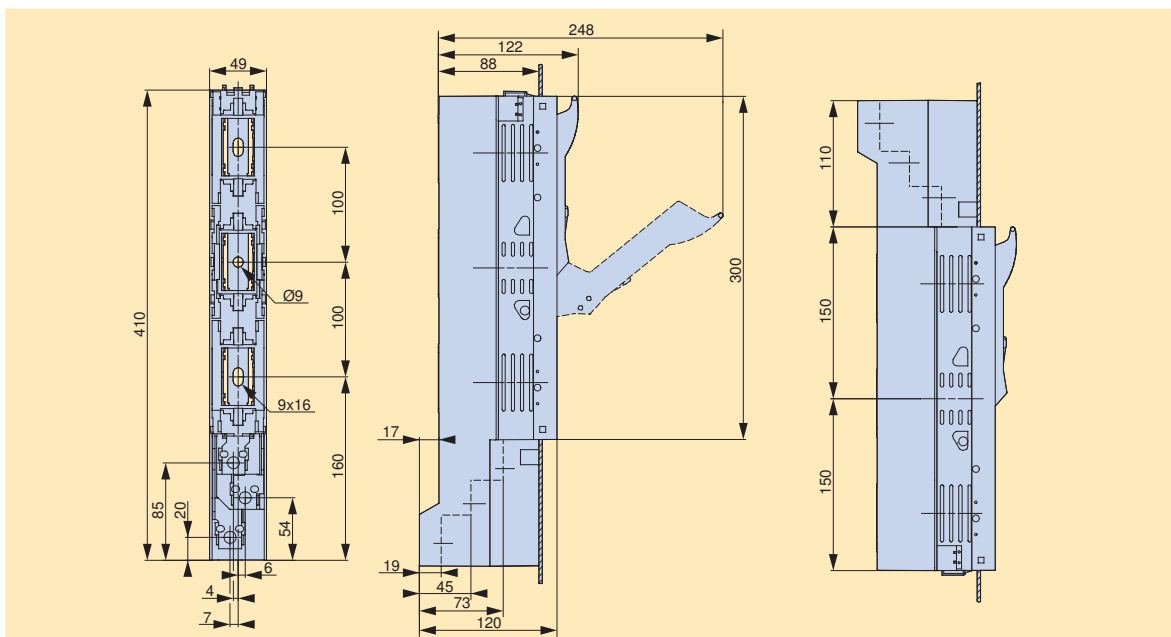

Typ/Type	Artikel-Nr./Article-No.	Seite/Page	Typ/Type	Artikel-Nr./Article-No.	Seite/Page
SL00-3X/185/F	L5461001	SL-15	SL00-3X/185/F	L5061001	SL-15
SL00-3X/185/KU00	L5466002	SL-15	SL00-3X/185/KU00	L5066002	SL-15

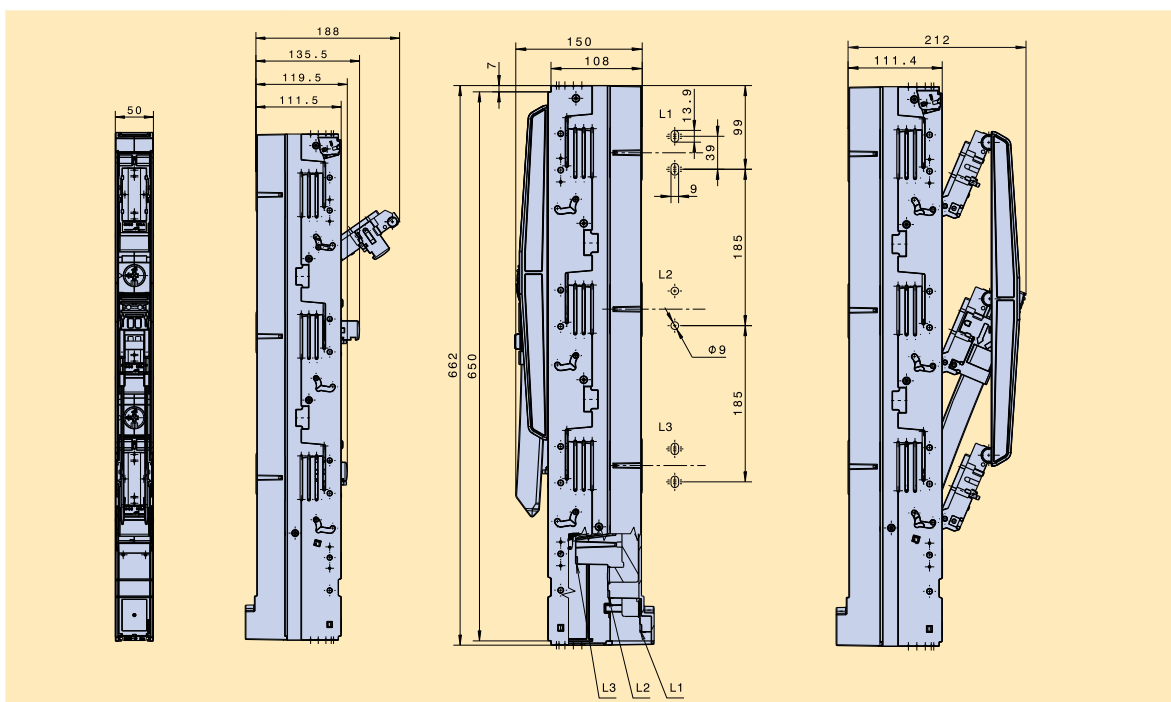

Typ/Type	Artikel-Nr./Article-No.	Seite/Page	Typ/Type	Artikel-Nr./Article-No.	Seite/Page
SL00-3X3/100/F/HA/ES00	L5051700	SL-13	SL00-3X3/100/F/HA/ES00/W	L5351707	SL-29

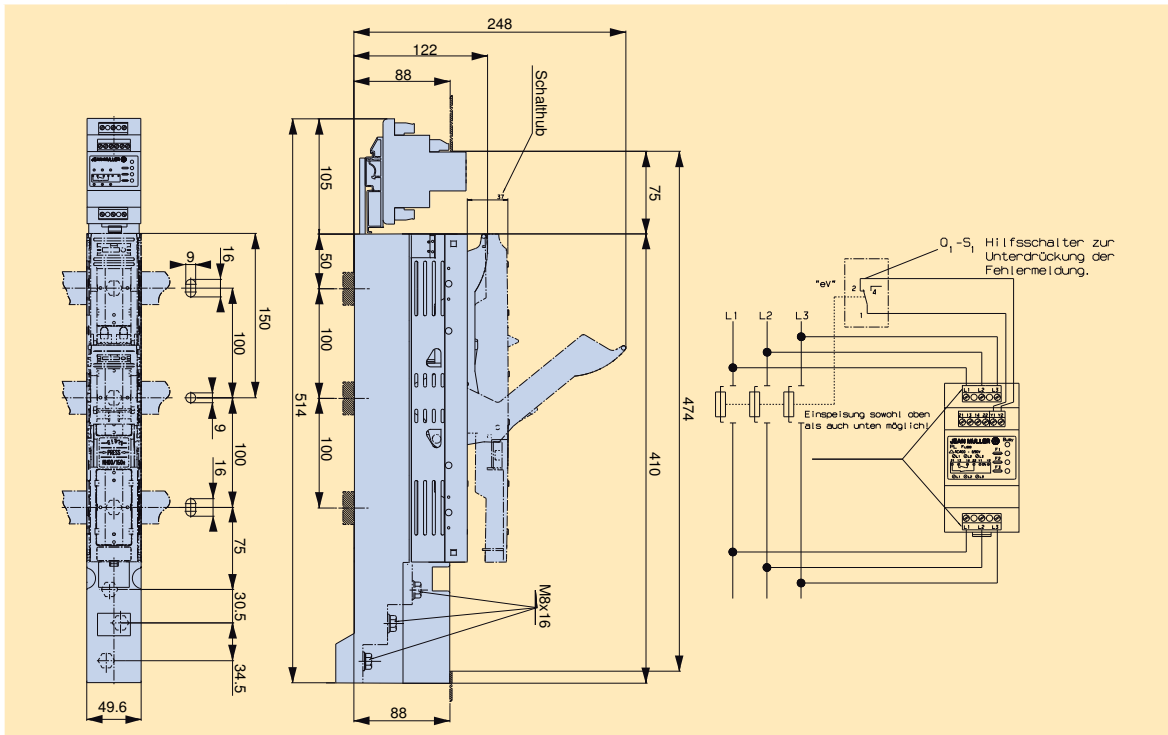

NH-Sicherungs-
leisten
*NH strip-
fuseways*

NH-Sicherungs-
lastschaltleisten
*NH strip-
fuse-switch-
disconnectors*

NH-Sicherungs-
lasttrennschalter
*NH fuseswitch-
disconnectors*

Typ/Type	Artikel-Nr./Article-No.	Seite/Page
2xSL00-3X3/100/AL185/ES00	L5051720	SL-13

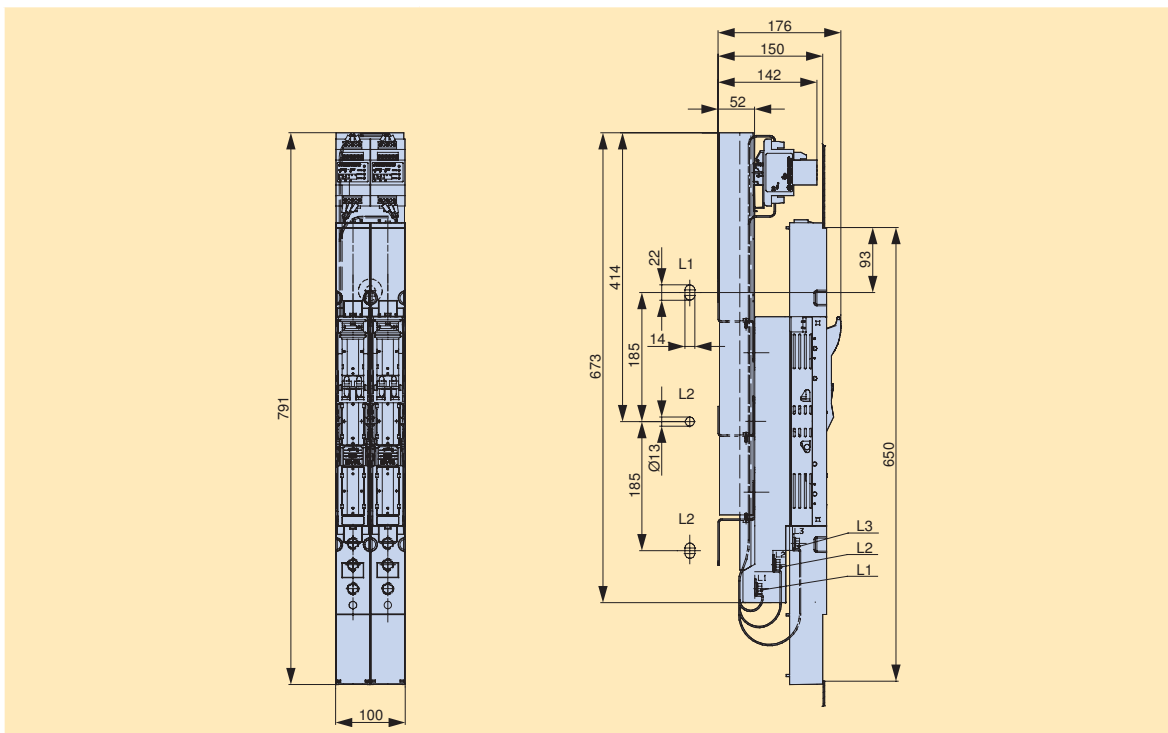

C|O|S|I|M|O®
C|O|S|I|M|O®

Klemmen
Terminals

Anhang
Appendix

NH-Sicherungslastschaltleisten

NH strip-type fuse-switch-disconnectors

Typ/Type	Artikel-Nr./Article-No.		Seite/Page	Typ/Type	Artikel-Nr./Article-No.		Seite/Page
SL1(G)-3X/... (W)	L19...	L12...	SL-17,SL-19	SL2-3X3/... (W)	L20...	L23...	SL-20
SL1-3X3/... (W)	L10...	L13...	SL-20	SL3-3X/... (W)	L39...	L32...	SL-19
SL2(G)-3X/... (W)	L29...	L22...	SL-17,SL-19	SL3-3X3/... (W)	L30...	L33...	SL-20

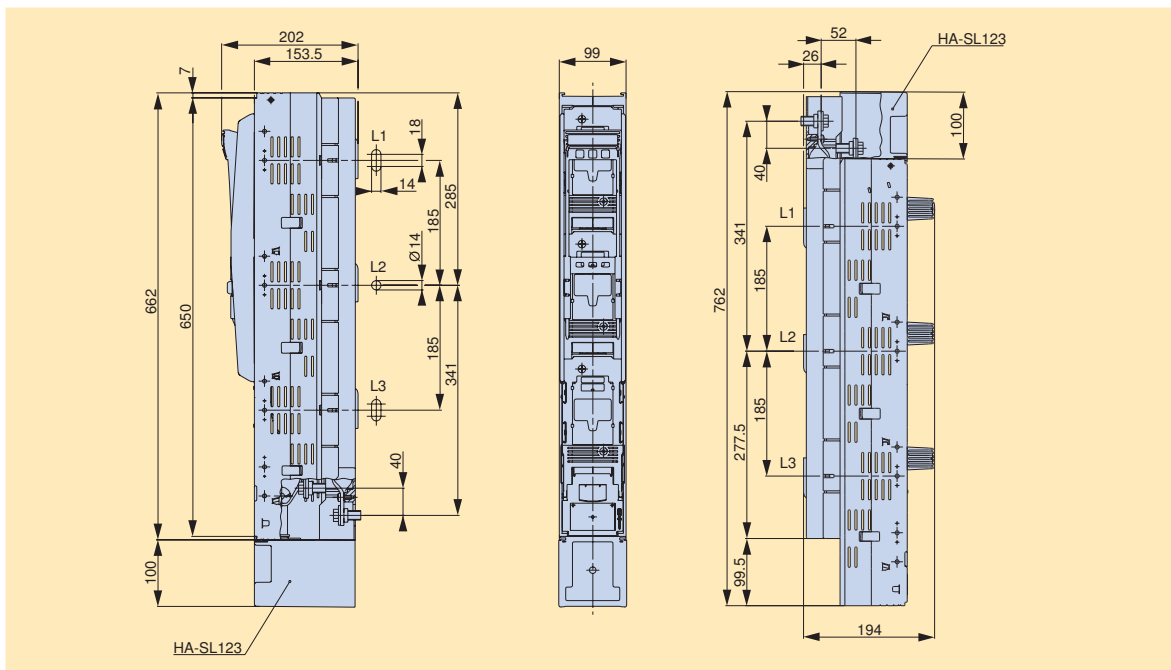

Typ/Type	Artikel-Nr./Article-No.		Seite/Page	Typ/Type	Artikel-Nr./Article-No.		Seite/Page
SL2(G)-3X/.../GV	L29...	L22...	SL-17, SL-19	SL3-3X/.../GV	L3931005		SL-19

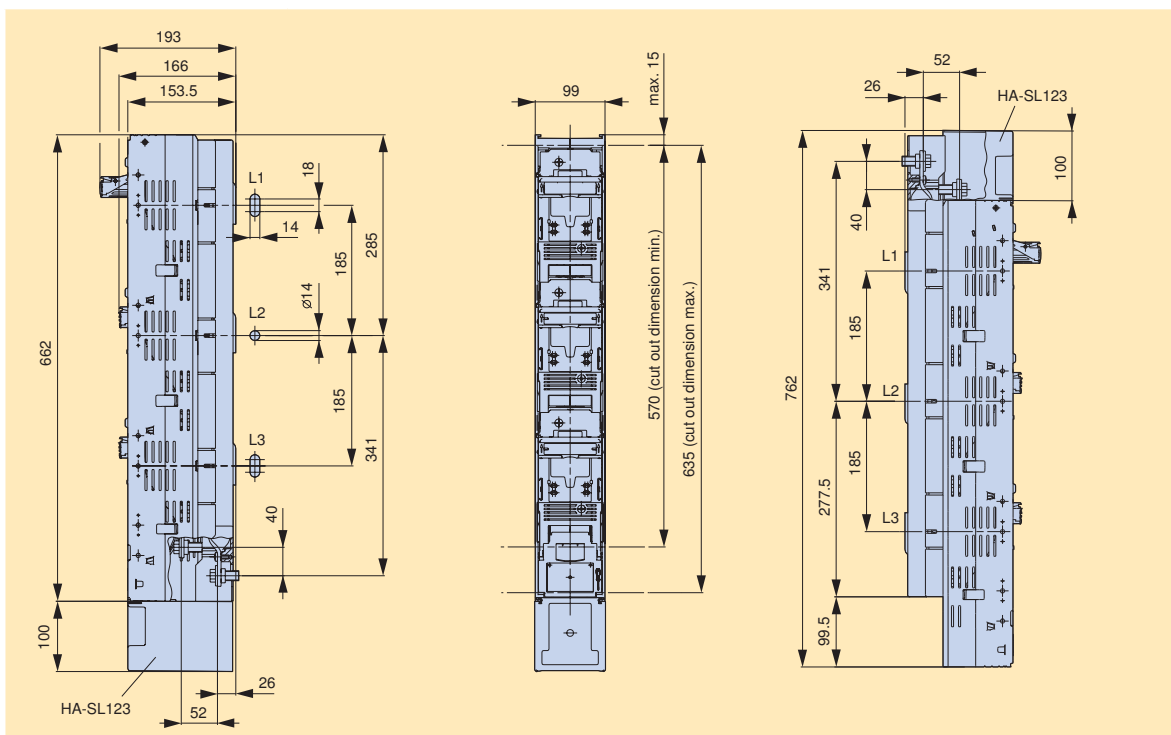

Typ/Type	Artikel-Nr./Article-No.	Seite/Page	Typ/Type	Artikel-Nr./Article-No.	Seite/Page
SL1-3X3/3A/ES00	L1031720	SL-20	SL3-3X3/3A/ES00	L3031720	SL-20
SL2-3X3/3A/ES00	L2031720	SL-20	-	-	-

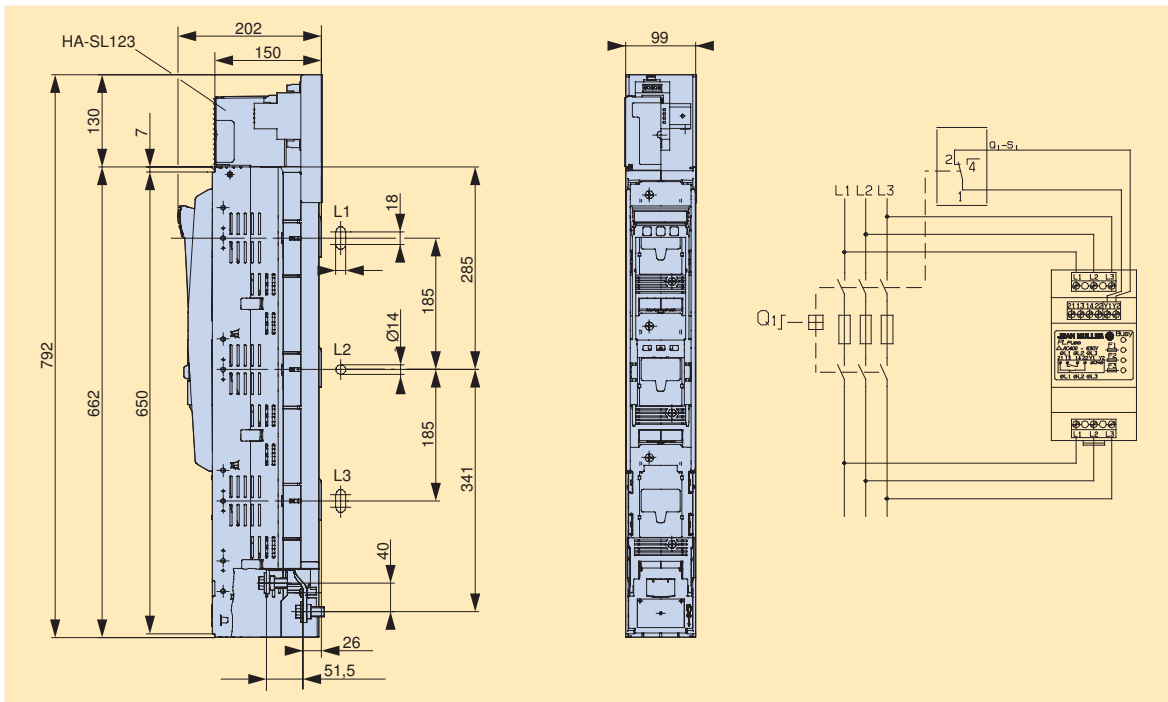

NH-Sicherungs-
leisten
*NH strip-
fuseways*

NH-Sicherungs-
lastschaltleisten
*NH strip-
type fuse-switch-
disconnectors*

NH-Sicherungs-
lasttrennschalter
*NH fuseswitch-
disconnectors*

Typ/Type	Artikel-Nr./Article-No.	Seite/Page	Typ/Type	Artikel-Nr./Article-No.	Seite/Page
SLTL3-3X/1000/HA	L3921300	SL-21	SLTL3-3X3/1000/HA	L3021300	SL-21

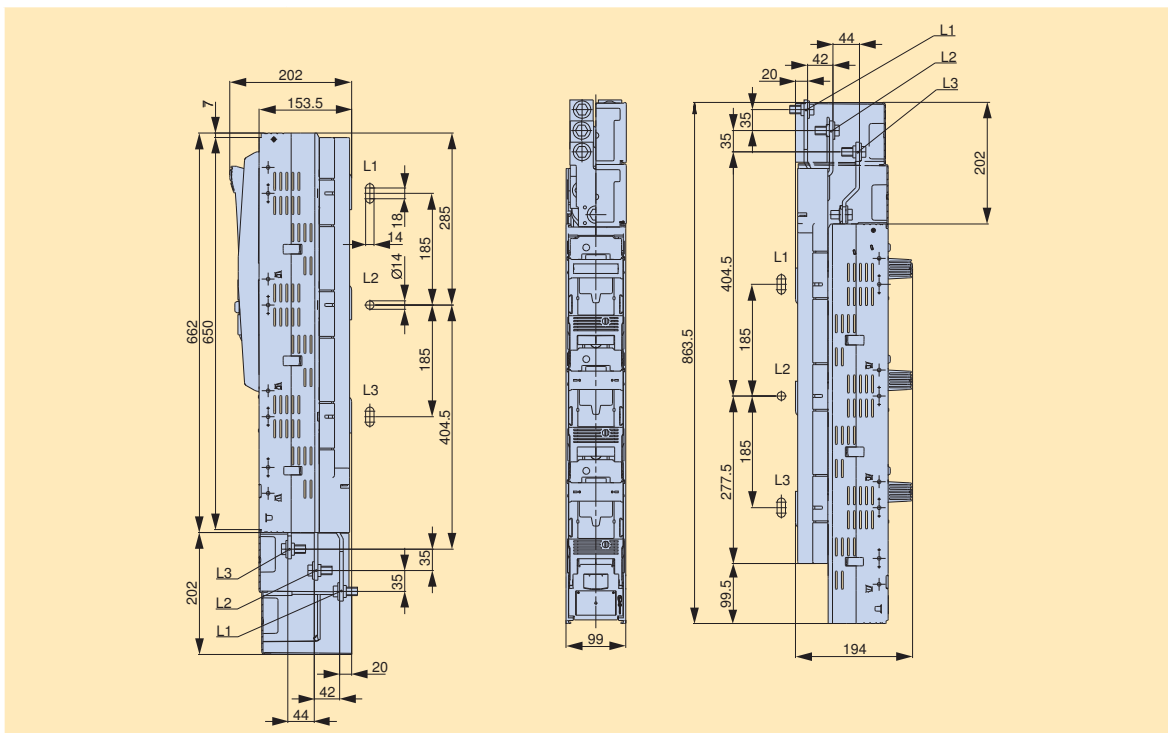

C|O|S|I|M|O®
C|O|S|I|M|O®

Klemmen
Terminals

Anhang
Appendix

NH-Sicherungslastschaltleisten

NH strip-type fuse-switch-disconnectors

Typ/Type	Artikel-Nr./Article-No.	Seite/Page	Typ/Type	Artikel-Nr./Article-No.	Seite/Page
SL3-3X/1000/ARO/TM3	L3920303	SL-21	SL3-3X3/910/ARO	L3020203	SL-23
SL3-3X3/1000/ARO/TM3	L3020303	SL-21	SL3-3X/910+/ARO	L392020399	SL-23
SL3-3X/910/ARO	L3920203	SL-23	SL3-3X3/910+ARO	L302020399	SL-23

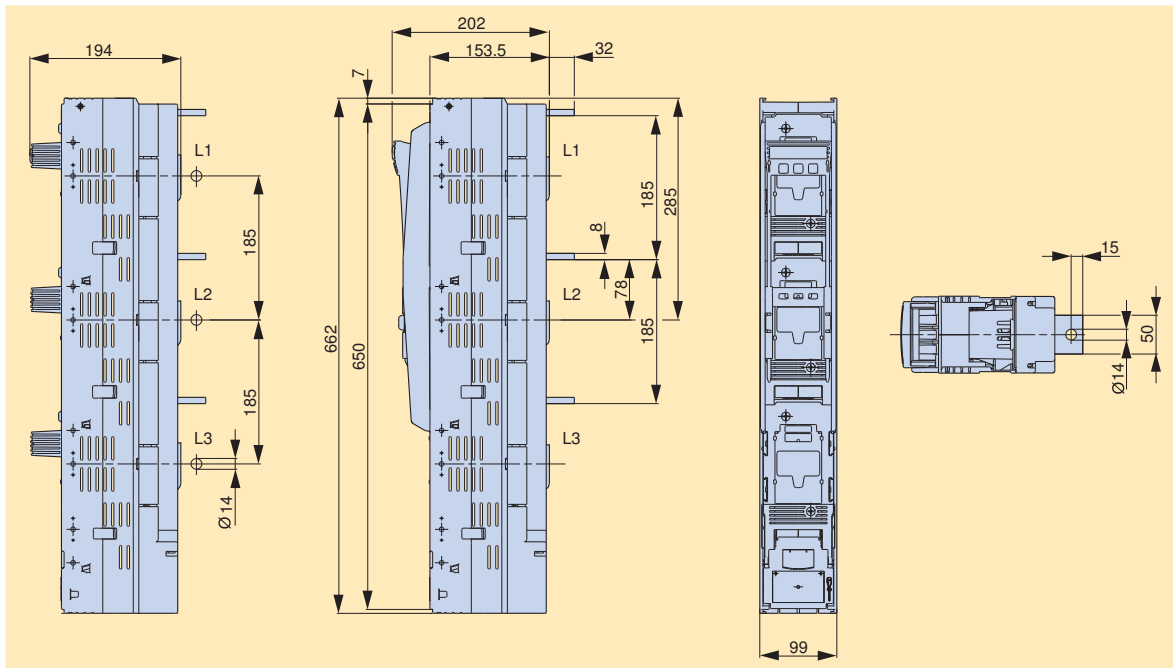

Typ/Type	Artikel-Nr./Article-No.	Seite/Page	Typ/Type	Artikel-Nr./Article-No.	Seite/Page
SL3-3X/910/HA	L3921200	SL-23	SL3-3X/910+/HA	L392120099	SL-23
SL3-3X3/910/HA	L3021200	SL-23	SL3-3X3/910+/HA	L302120099	SL-23

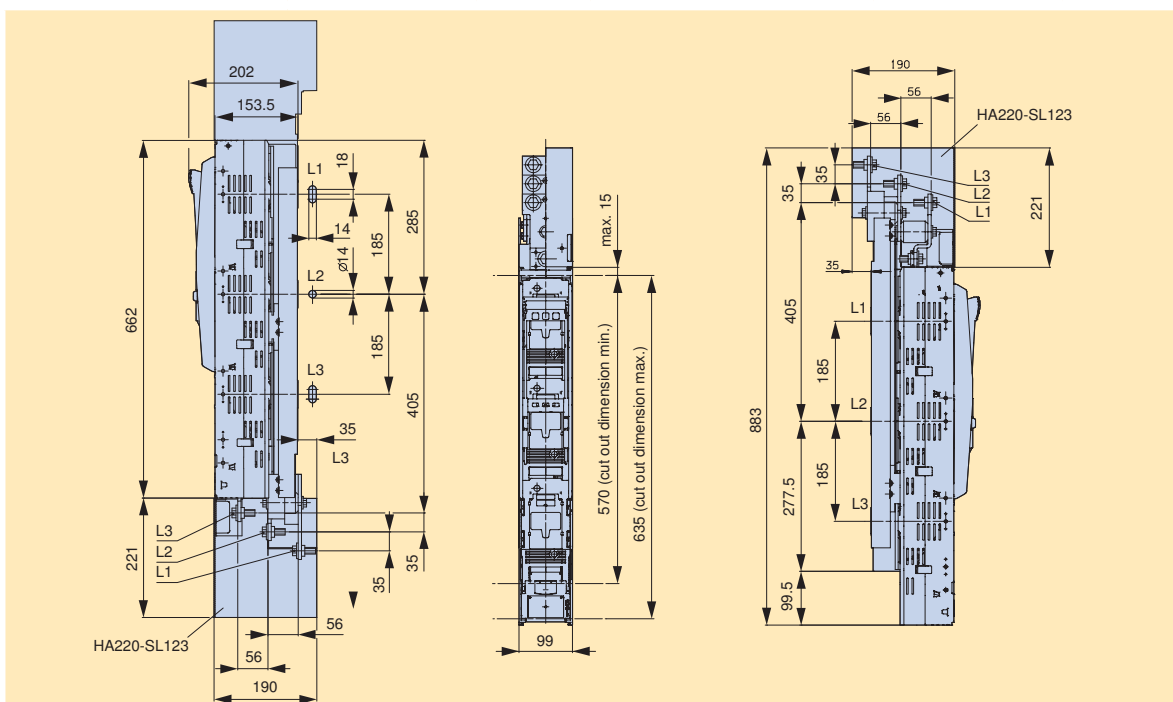

Typ/Type	Artikel-Nr./Article-No.	Seite/Page	Typ/Type	Artikel-Nr./Article-No.	Seite/Page
SL3-3X/910/AO/AU-100	L3920208	SL-23	SL3-3X3/910/AO/AU-100	L3020208	SL-23

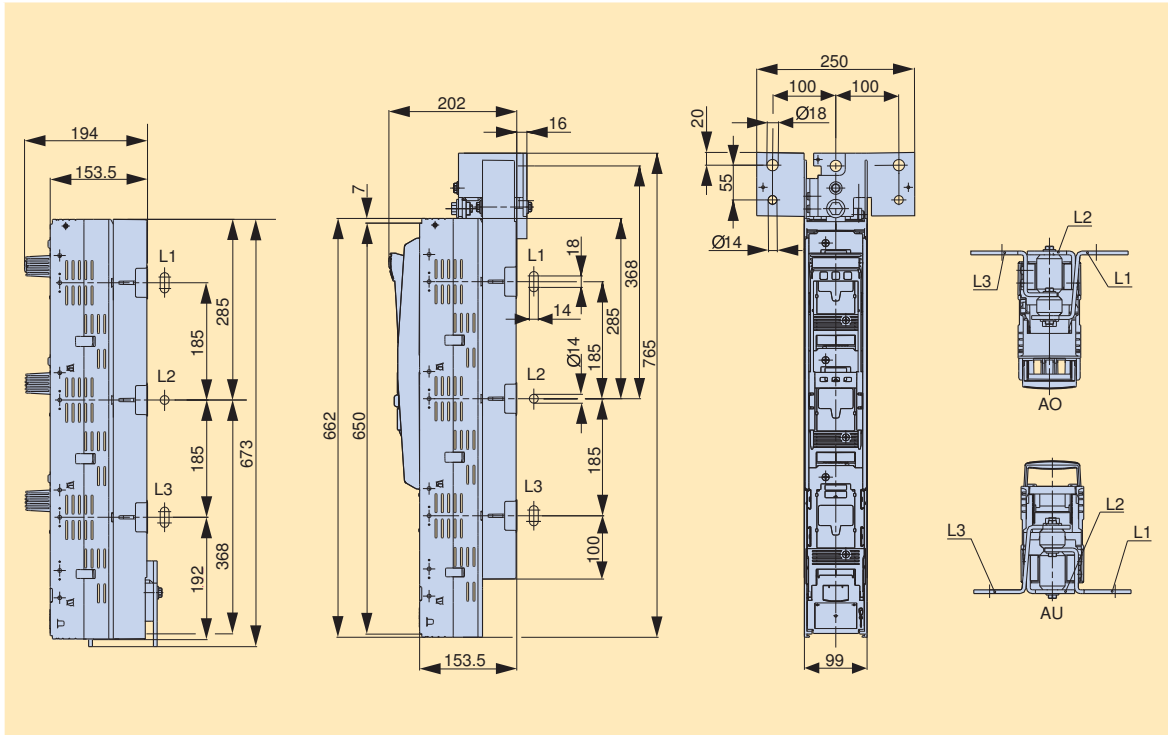

NH-Sicherungs-
leisten
*NH strip-
fuseways*

NH-Sicherungs-
lastschaltleisten
*NH strip-
type fuse-switch-
disconnectors*

NH-Sicherungs-
lasttrennschalter
*NH fuseswitch-
disconnectors*

Typ/Type	Artikel-Nr./Article-No.	Seite/Page	Typ/Type	Artikel-Nr./Article-No.	Seite/Page
SL3-3X/910/AO/AU-75	L3920210	SL-23	SL3-3X3/910/AO/AU-75	L3020210	SL-23

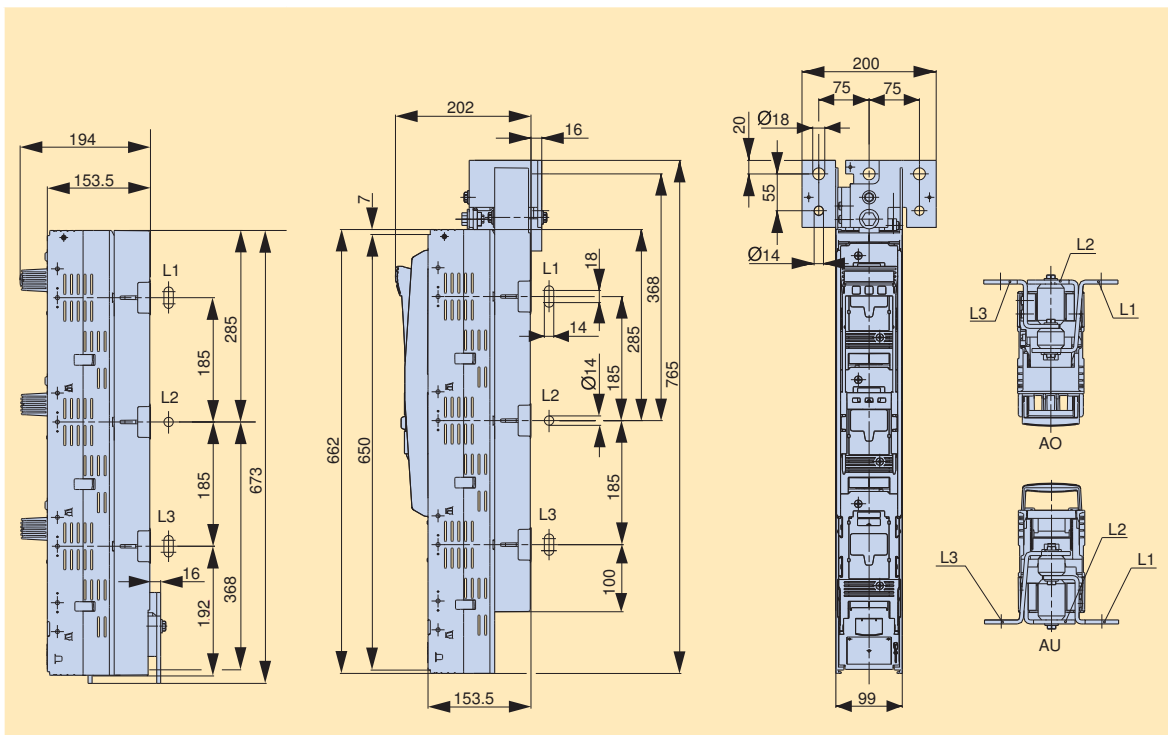

C|O|S|I|M|O®
C|O|S|I|M|O®

Klemmen
Terminals

Anhang
Appendix

NH-Sicherungslastschaltleisten

NH strip-type fuse-switch-disconnectors

Typ/Type	Artikel-Nr./Article-No.	Seite/Page	Typ/Type	Artikel-Nr./Article-No.	Seite/Page
SL3-3X/910/ARO/110	L3920206	SL-23	SL3-3X3/910/ARO/110	L3020218	SL-23

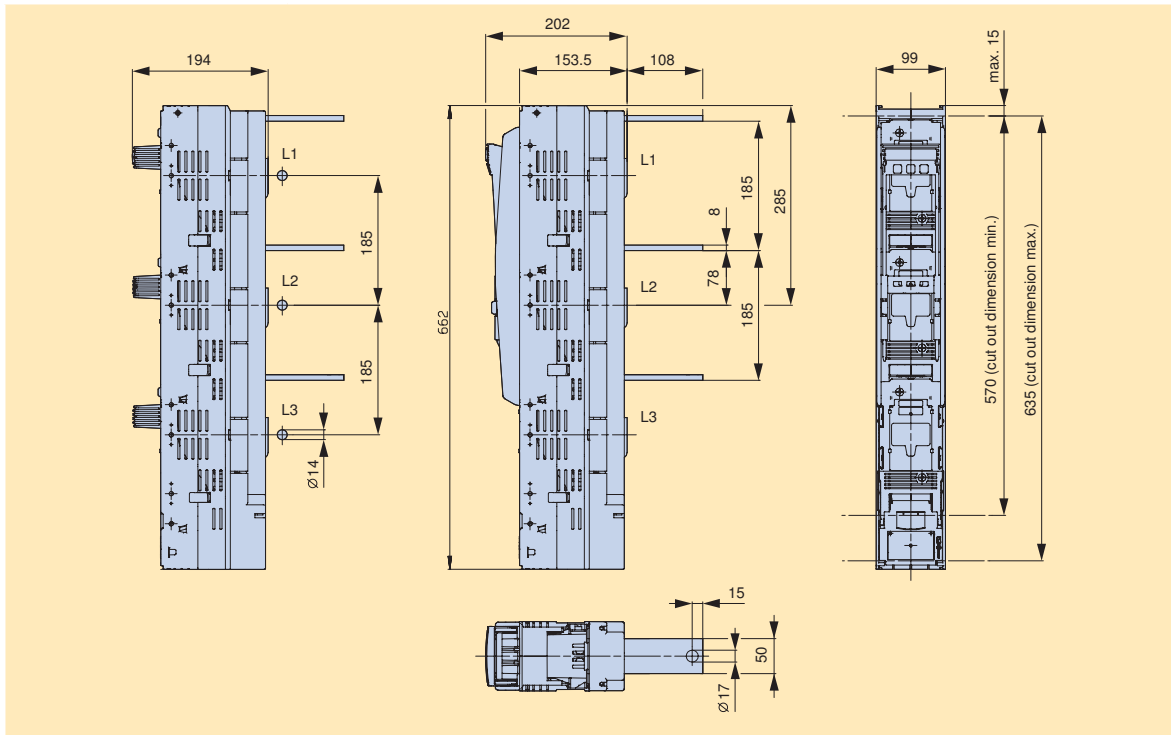

Typ/Type	Artikel-Nr./Article-No.	Seite/Page	Typ/Type	Artikel-Nr./Article-No.	Seite/Page
SL3-3X/910/AORL	L3920220	SL-23	SL3-3X3/910/AORL	L3020216	SL-23

Für Wandler Typ WSD50./
For current-transformer type WSD50.

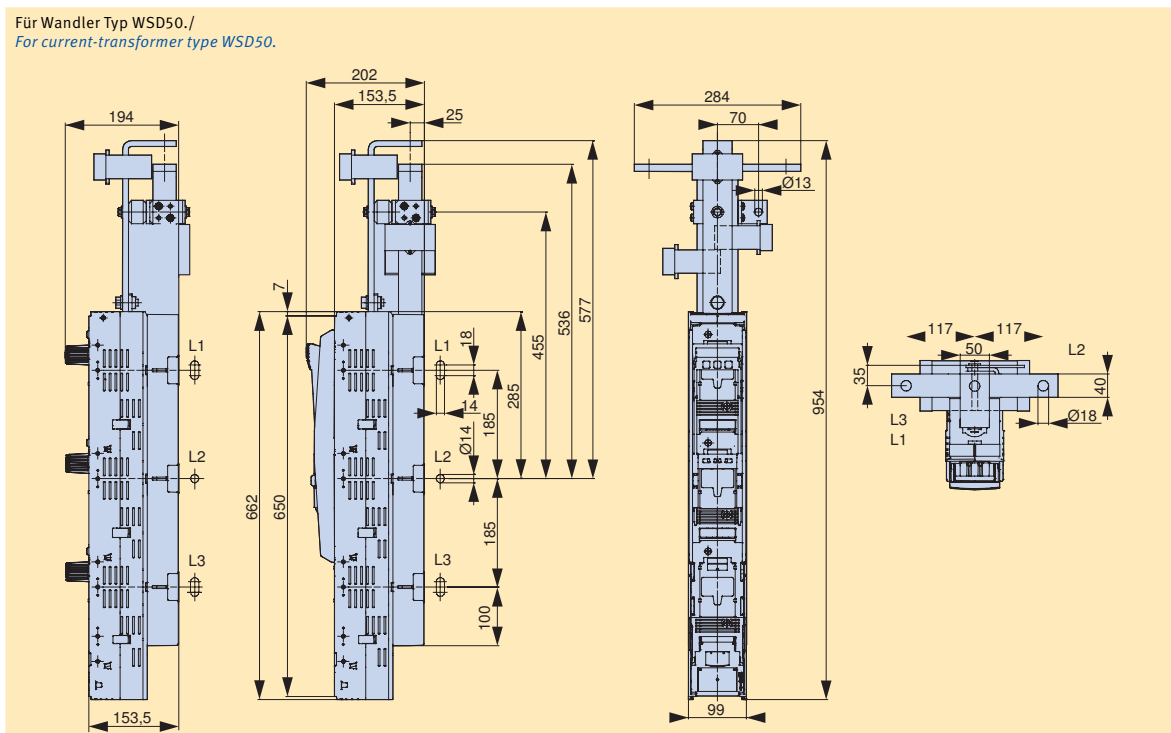

Typ/Type	Artikel-Nr./Article-No.	Seite/Page
SL3-3X3/910/AO-102	L3021229	SL-23

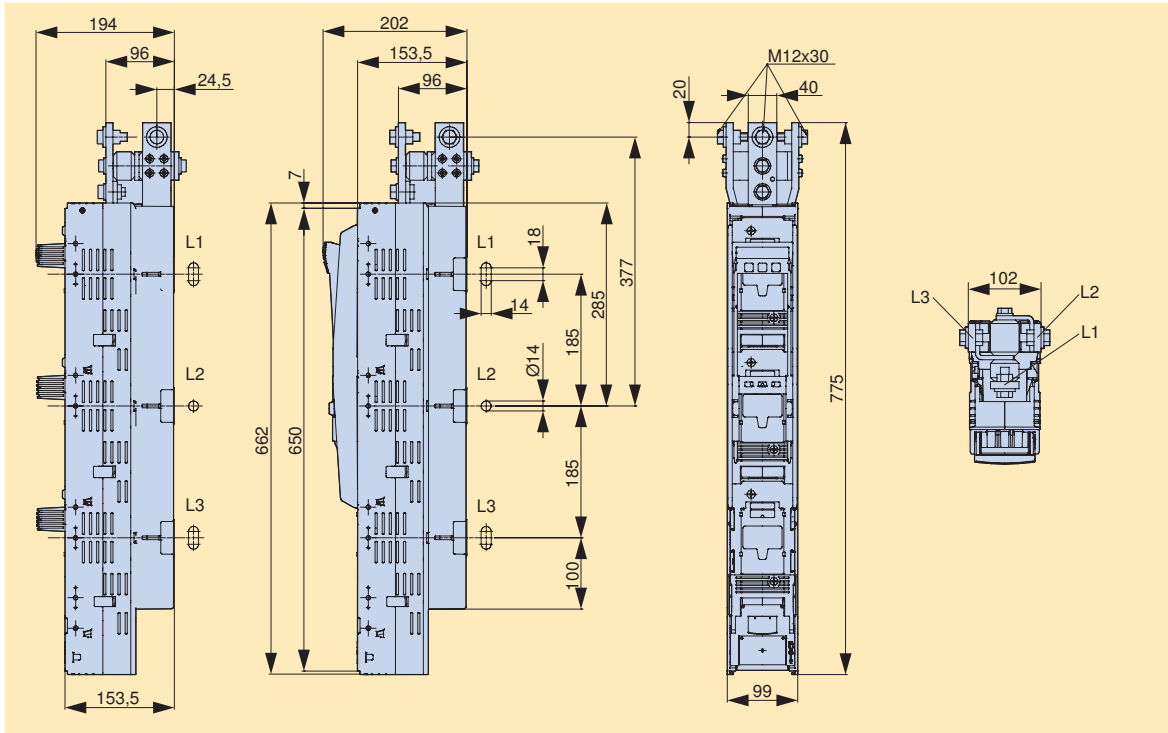

NH-Sicherungs-
leisten
*NH strip-
fuseways*

NH-Sicherungs-
lastschaltleisten
*NH strip-
fuse-switch-
disconnectors*

NH-Sicherungs-
lasttrennschalter
*NH fuseswitch-
disconnectors*

Typ/Type	Artikel-Nr./Article-No.	Seite/Page	Typ/Type	Artikel-Nr./Article-No.	Seite/Page
SL3-3X/910/ARUS	L3920204	SL-23	SL3-3X3/910/ARUS	L3020204	SL-23

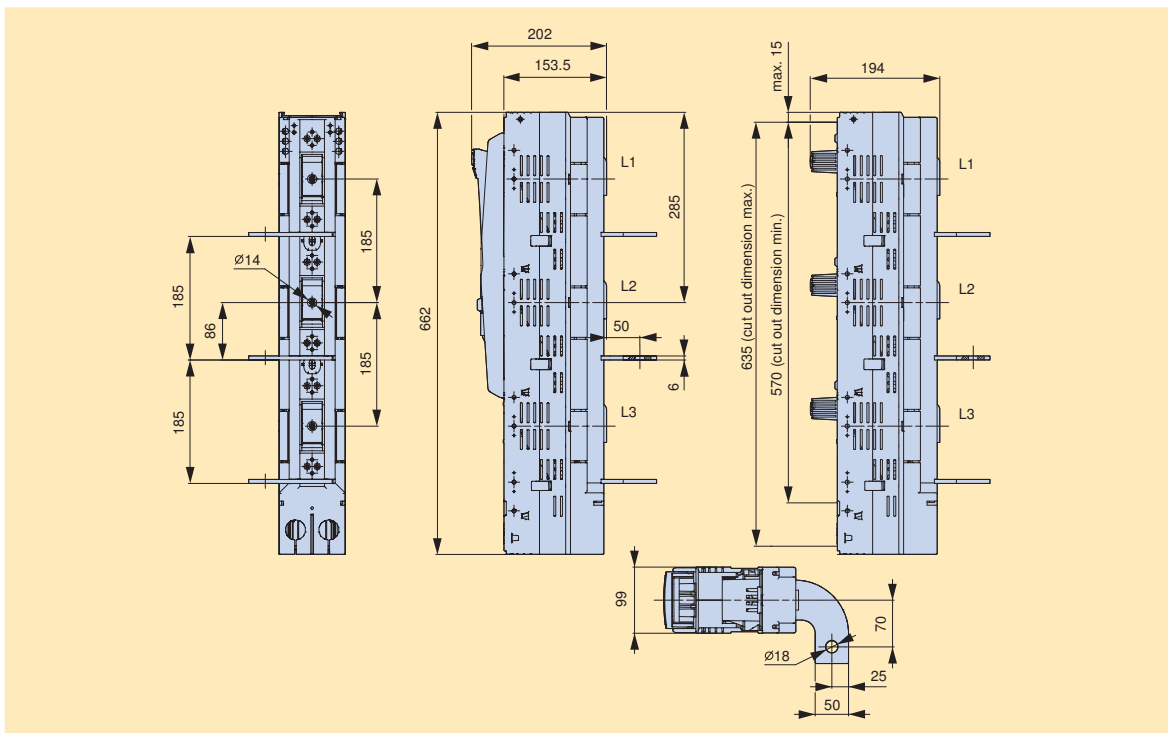

C|O|S|I|M|O®
CIOISIMIO®

Klemmen
Terminals

Anhang
Appendix

NH-Sicherungslastschaltleisten

NH strip-type fuse-switch-disconnectors

Typ/Type	Artikel-Nr./Article-No.	Seite/Page	Beschreibung/Description	Artikel-Nr./Article-No.	Seite/Page
SL3-3X2/1250/HA	L3921400	SL-19	SLTL3-3X2/1600/HA	L3921402	SL-21
SL3-3X6/1250/HA	L3021400	SL-20	SLTL3-3X6/1600/HA	L3021401	SL-21

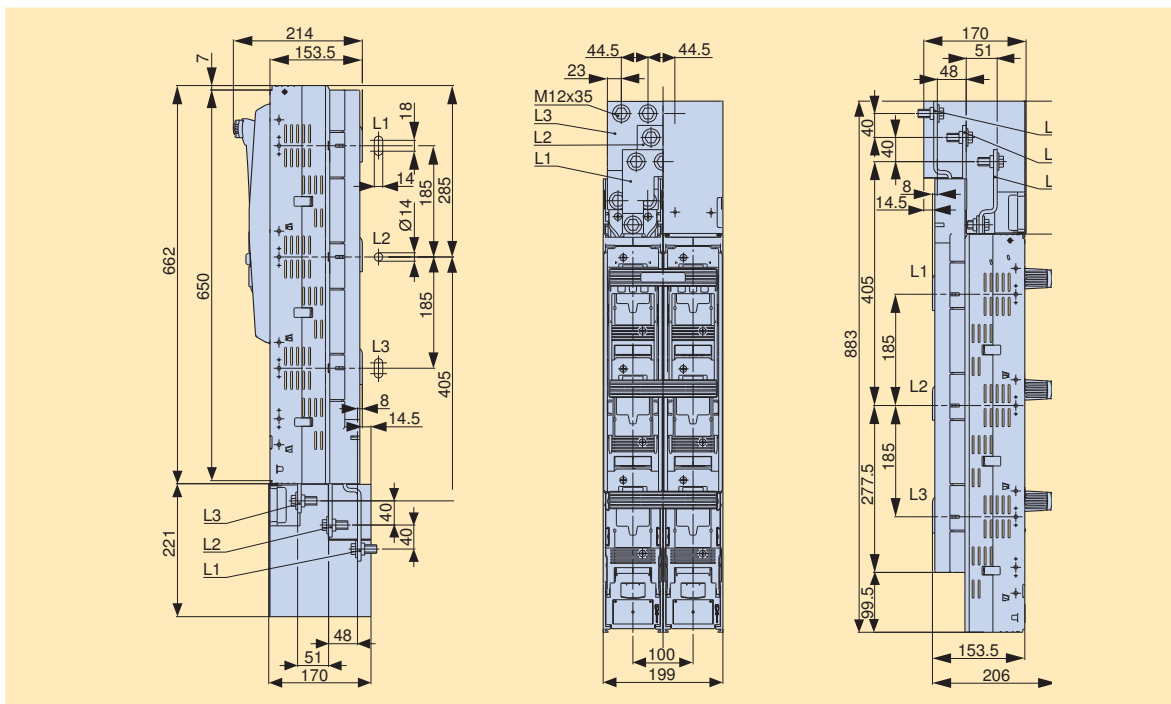

Typ/Type	Artikel-Nr./Article-No.	Seite/Page	Beschreibung/Description	Artikel-Nr./Article-No.	Seite/Page
SLTL3-3X2/2000/HA	L3921507	SL-21	SLTL3-3X6/2000/HA	L3021501	SL-21

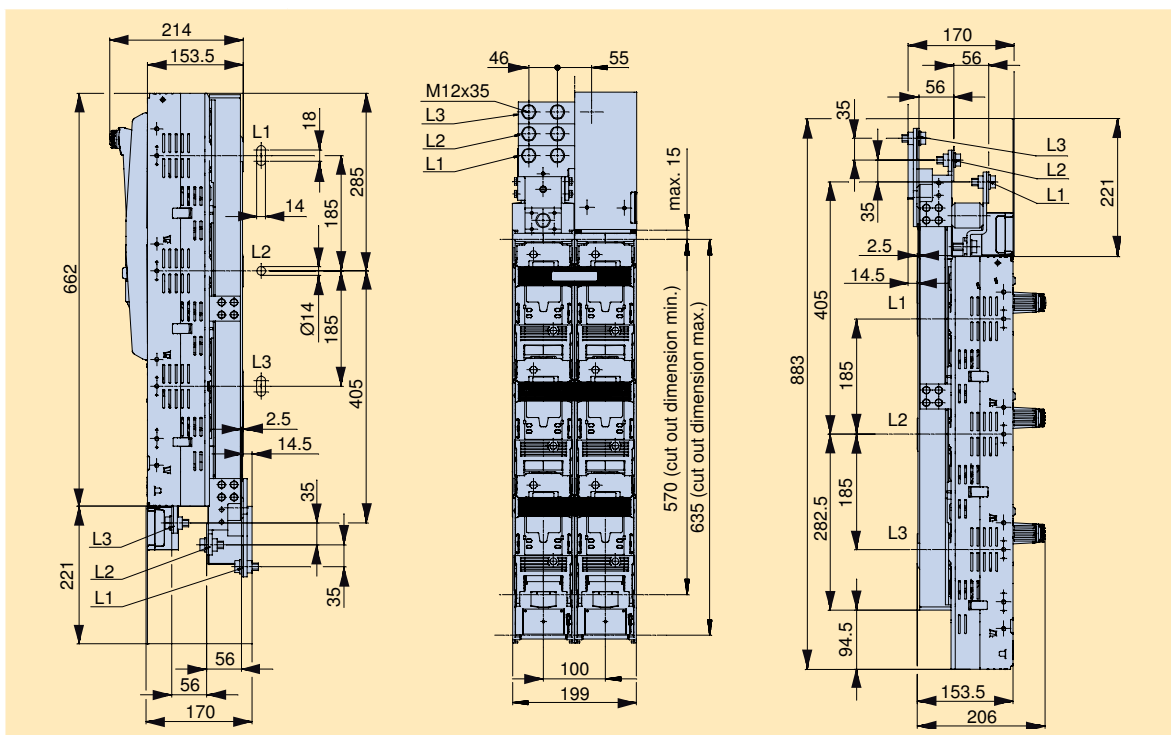

Typ/Type	Artikel-Nr./Article-No.	Seite/Page	Typ/Type	Artikel-Nr./Article-No.	Seite/Page
SLTL4A-3AS/3X/4	L4941000	SL-25	SLTL4A-3AS/3X/4/AO	L4941001	SL-25

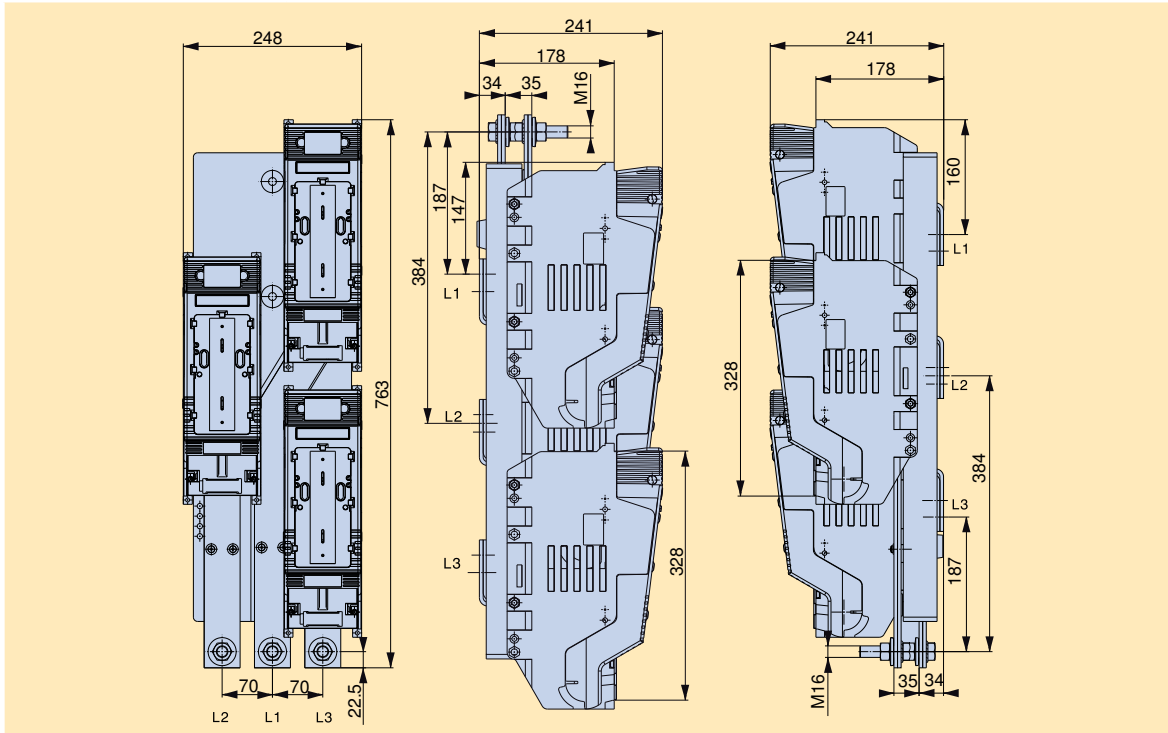

NH-Sicherungs-
leisten
*NH strip-
fuseways*

NH-Sicherungs-
lastschaltleisten
*NH strip-
type fuse-switch-
disconnectors*

NH-Sicherungs-
lasttrennschalter
*NH fuseswitch-
disconnectors*

C|O|S|I|M|O®
CIOISIMIO®

Klemmen
Terminals

Anhang
Appendix

NH-Sicherungslastschaltleisten

NH strip-type fuse-switch-disconnectors

Typ/Type	Artikel-Nr./Article-No.	Seite/Page	Beschreibung/Description	Artikel-Nr./Article-No.	Seite/Page
SLT3-3SL/3X...	L390000..	SL-25	SLT3-3SL/3X3...	L300000...	SL-25
SLT3-3SR/3X...	L390000...	SL-25	SLT3-3SR/3X3...	L300000...	SL-25

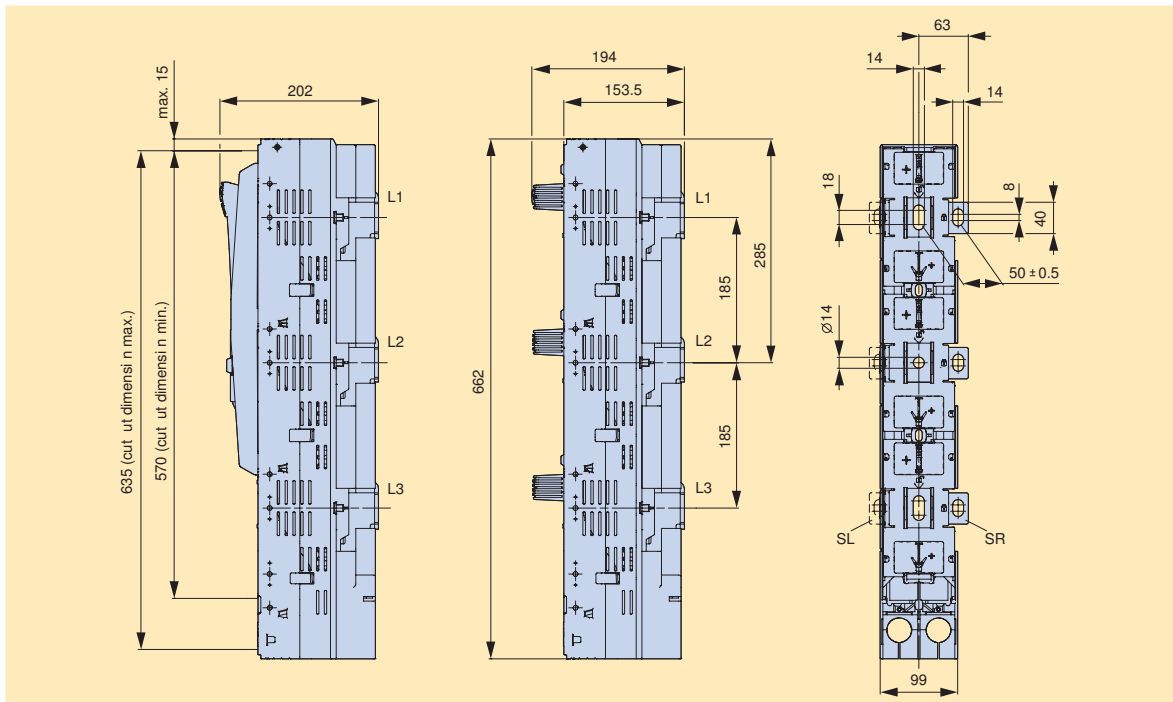

Typ/Type	Artikel-Nr./Article-No.	Seite/Page	Typ/Type	Artikel-Nr./Article-No.	Seite/Page
SLT3-3SR/3X6/2000/TM3	L3000501	SL-25	SLT3-3SR/3X2/2000/TM3	L3900501	SL-25

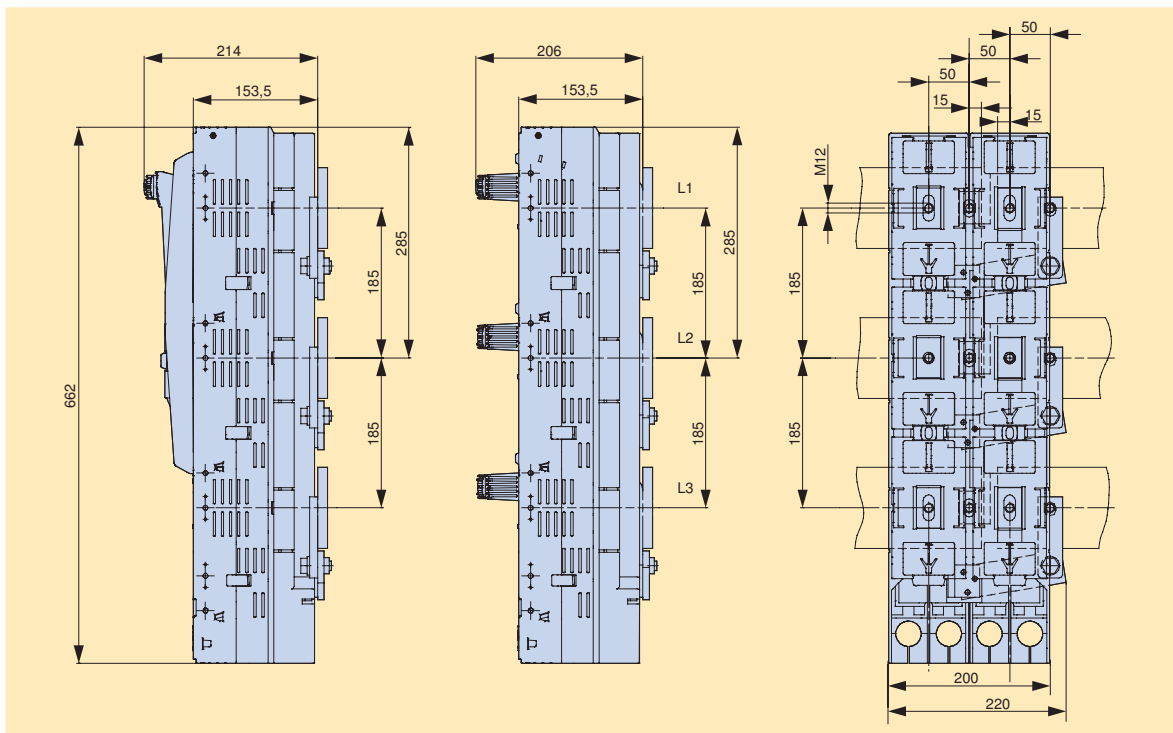

Typ/Type	Artikel-Nr./Article-No.	Seite/Page
AB-SL00/1	L8500262	SL-33

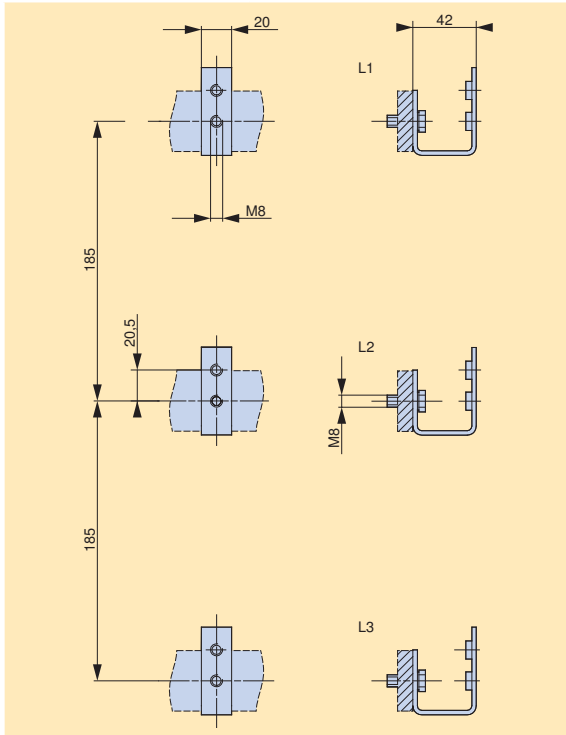

Typ/Type	Artikel-Nr./Article-No.	Seite/Page
AB185-SL00/100/1/52	L8600912	SL-33

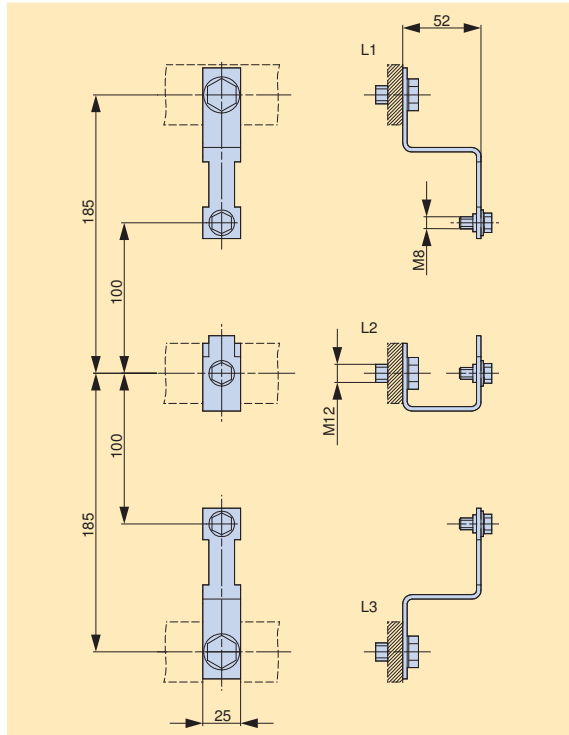

Typ/Type	Artikel-Nr./Article-No.	Seite/Page
AB60-SL00/100/1	L8600178	SL-33

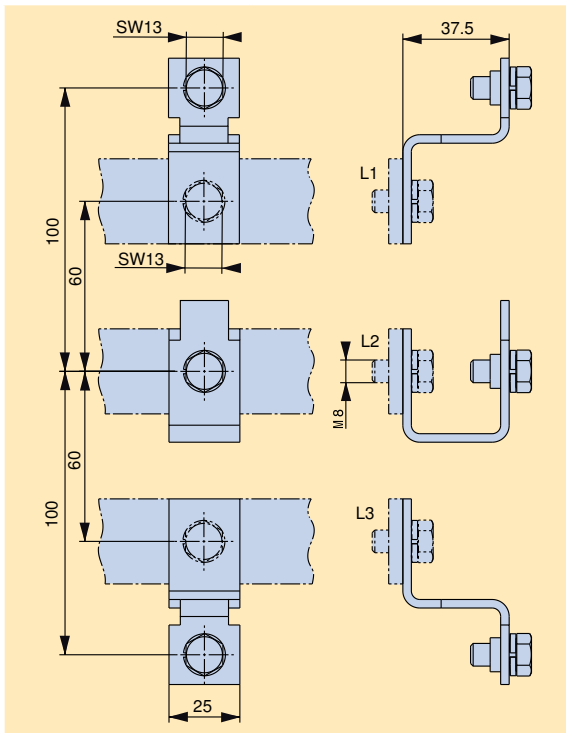

Typ/Type	Artikel-Nr./Article-No.	Seite/Page
AL-SL00/42	L8500605	SL-33

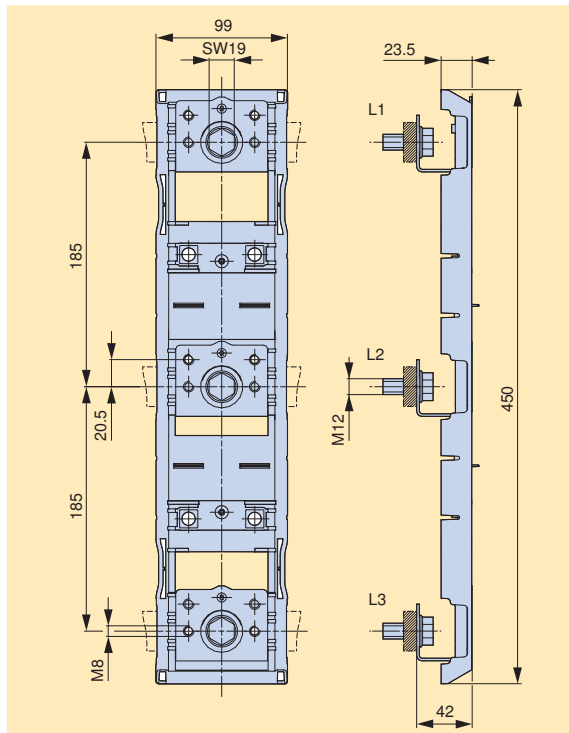

NH-Sicherungs-
leisten
*NH strip-
fuseways*

NH-Sicherungs-
lastschaltleisten
*NH strip-
fuse-switch-
disconnectors*

NH-Sicherungs-
lasttrennschalter
*NH fuse-switch-
disconnectors*

C|O|S|I|M|O®
C|O|S|I|M|O®

Klemmen
Terminals

Anhang
Appendix

NH-Sicherungslastschaltleisten

NH strip-type fuse-switch-disconnectors

Typ/Type	Artikel-Nr./Article-No.	Seite/Page
AL185-SL00/100/52	L8500897	SL-33

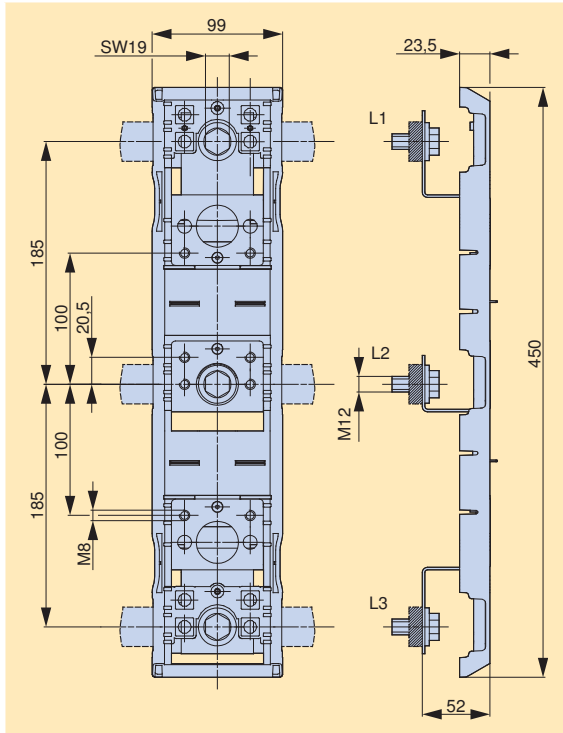

Typ/Type	Artikel-Nr./Article-No.	Seite/Page
AL185/SK-SL00/100/52	L8500898	SL-33

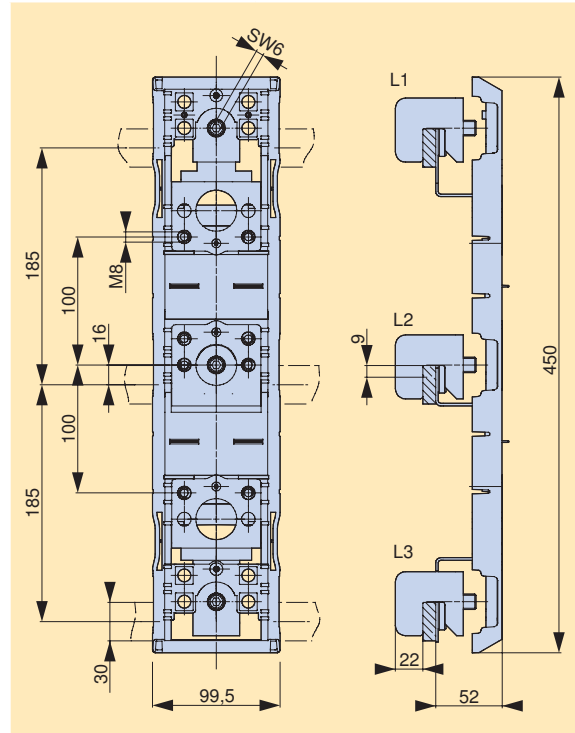

Typ/Type	Artikel-Nr./Article-No.	Seite/Page
AL/SK-SL00/42	L8500852	SL-33

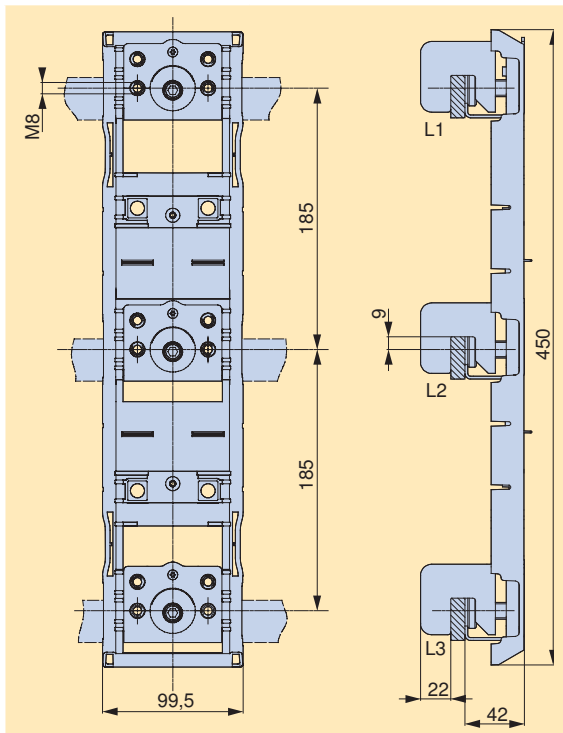

Typ/Type	Artikel-Nr./Article-No.	Seite/Page
HRV/KM2.../gelb/yellow	L8990573	SL-33

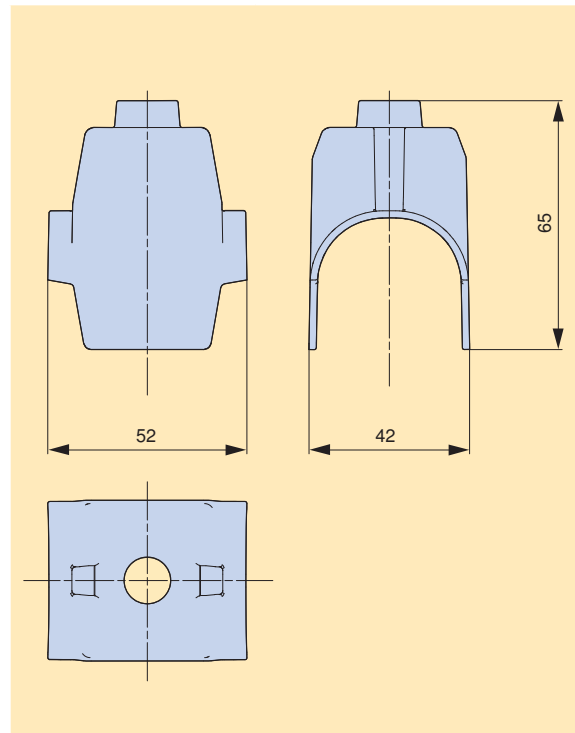

Typ/Type	Artikel-Nr./Article-No.	Seite/Page
HA-SL00/185	L8551087	SL-34
HA/HO-SL00/185	L8551091	SL-34

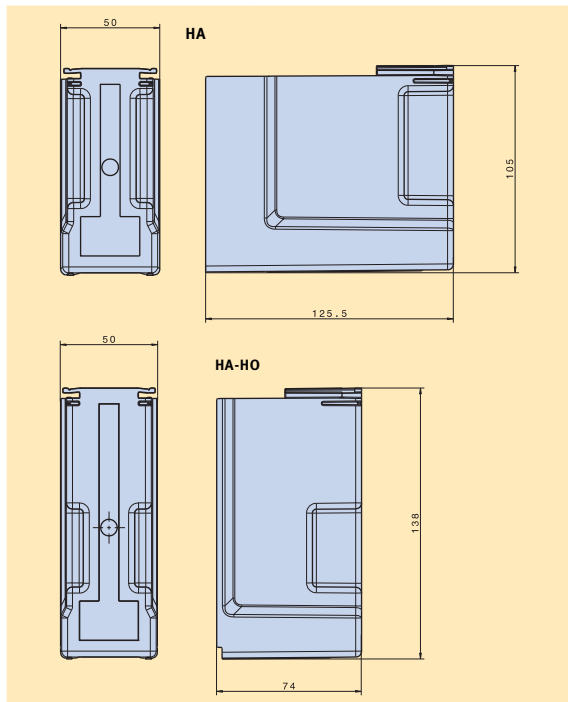

Typ/Type	Artikel-Nr./Article-No.	Seite/Page
BO/BU-SL00/100	L8650896	SL-34

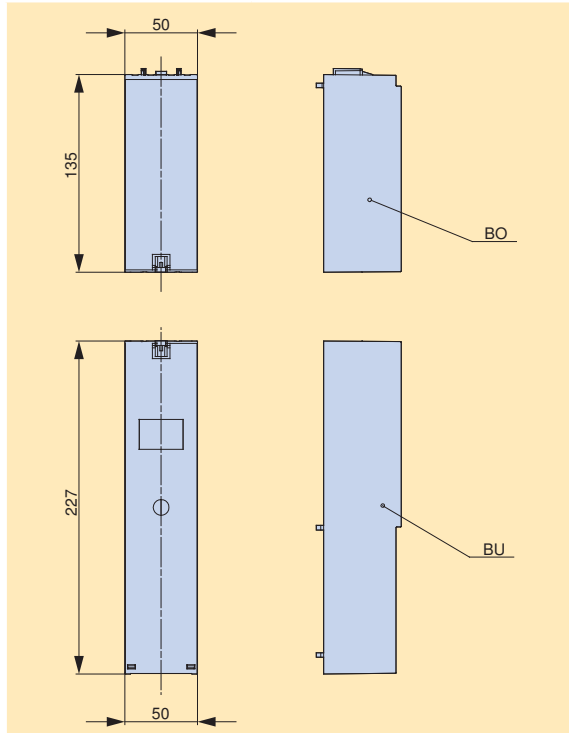

Typ/Type	Artikel-Nr./Article-No.	Seite/Page
HAV-SL00/100	L8650895	SL-34

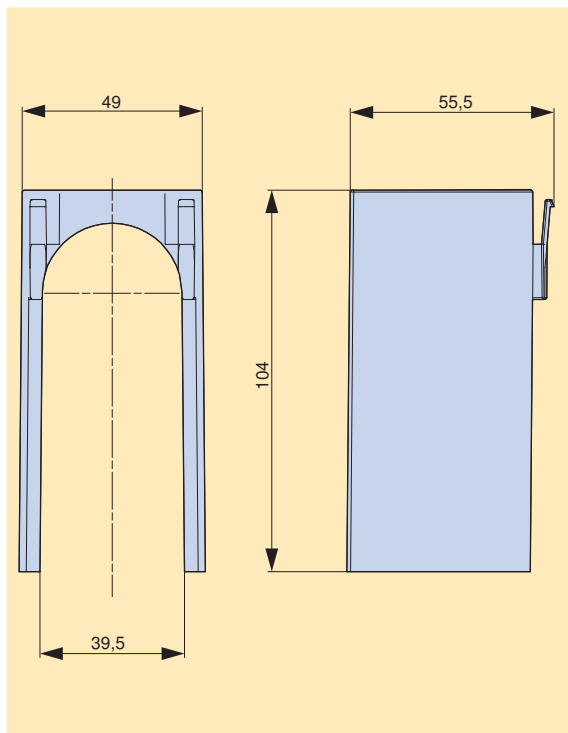

Typ/Type	Artikel-Nr./Article-No.	Seite/Page
HA-SL123/10	L8950666	SL-34

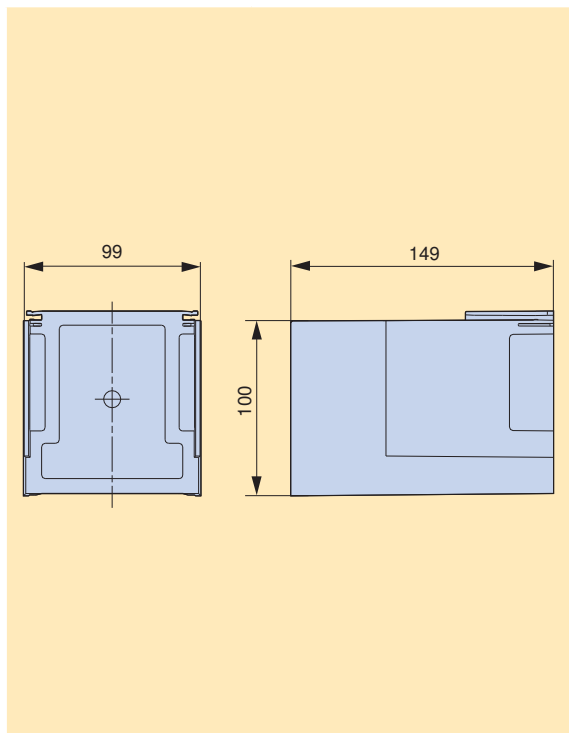

NH-Sicherungs-
leisten
*NH strip-
fuseways*

NH-Sicherungs-
lastschaltleisten
*NH strip-
type fuse-switch-
disconnectors*

NH-Sicherungs-
lasttrennschalter
*NH fuseswitch-
disconnectors*

C|O|S|I|M|O®
C|O|S|I|M|O®

Klemmen
Terminals

Anhang
Appendix

NH-Sicherungslastschaltleisten

NH strip-type fuse-switch-disconnectors

Typ/Type	Artikel-Nr./Article-No.	Seite/Page
HA-SL3X2/10	L8950675	SL-34

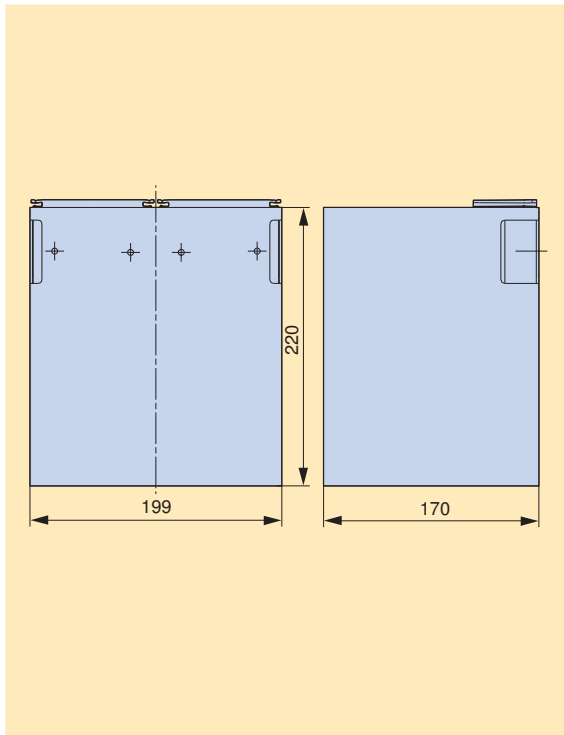

Typ/Type	Artikel-Nr./Article-No.	Seite/Page
HA220-SL123/10	L8950673	SL-34

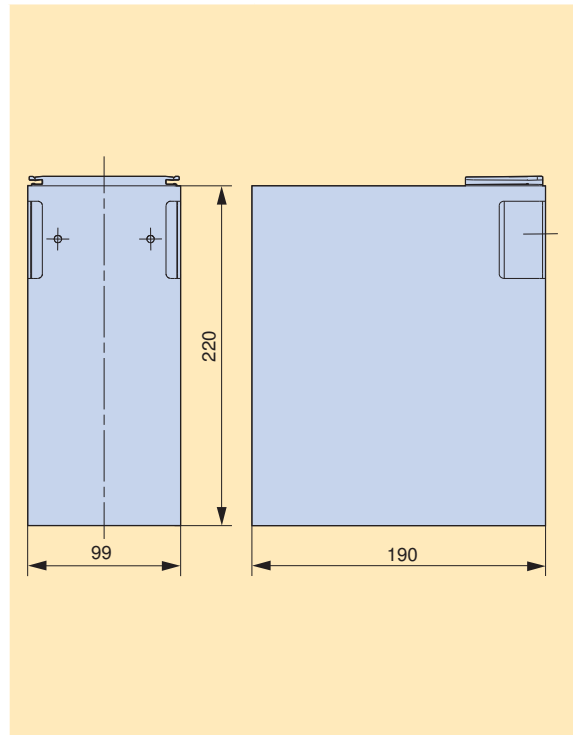

Typ/Type	Artikel-Nr./Article-No.	Seite/Page
HA275-SL123/10	L8950674	SL-34

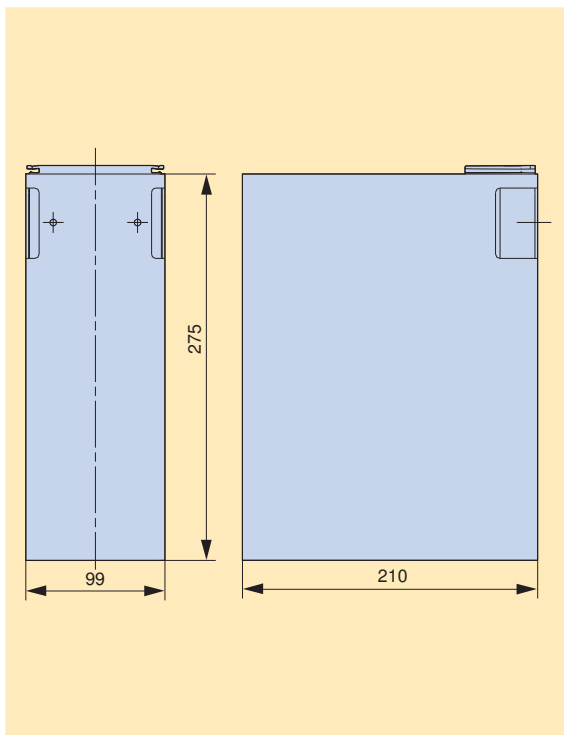

Typ/Type	Artikel-Nr./Article-No.	Seite/Page
B-SL00/100	L8520386	SL-34

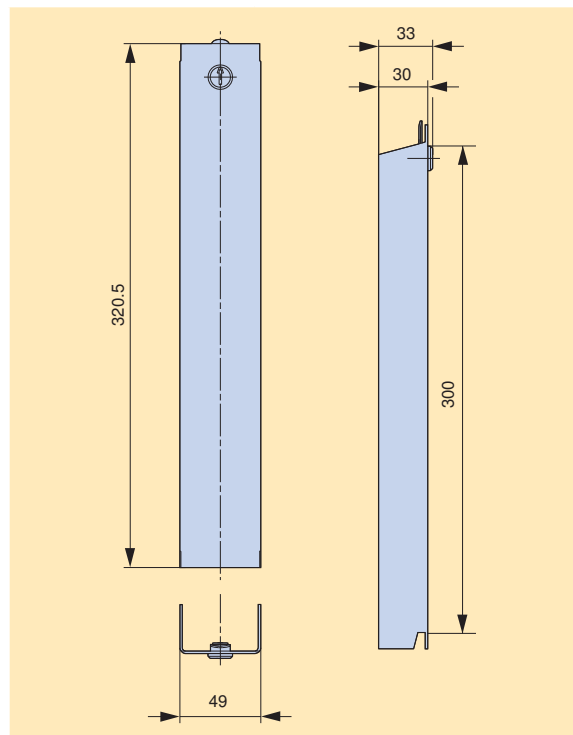

Typ/Type	Artikel-Nr./Article-No.	Seite/Page
B-SL00/650	L8590899	SL-34

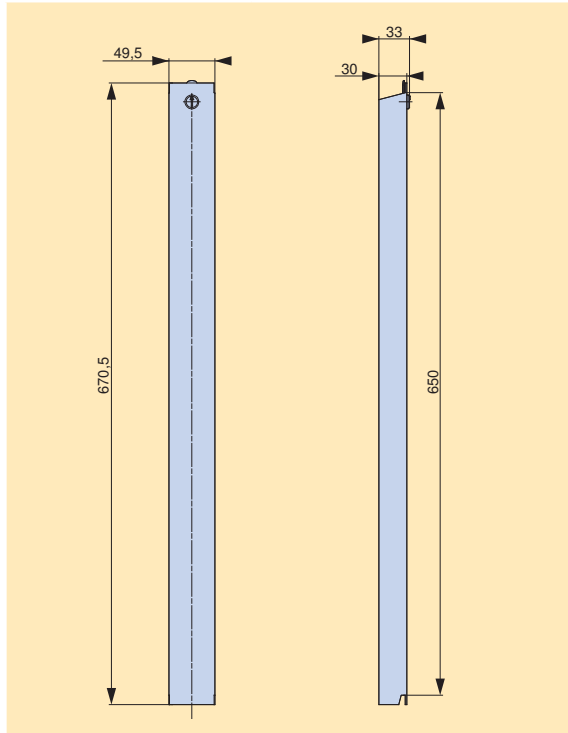

Typ/Type	Artikel-Nr./Article-No.	Seite/Page
B-SL123/650	L8920746	SL-34

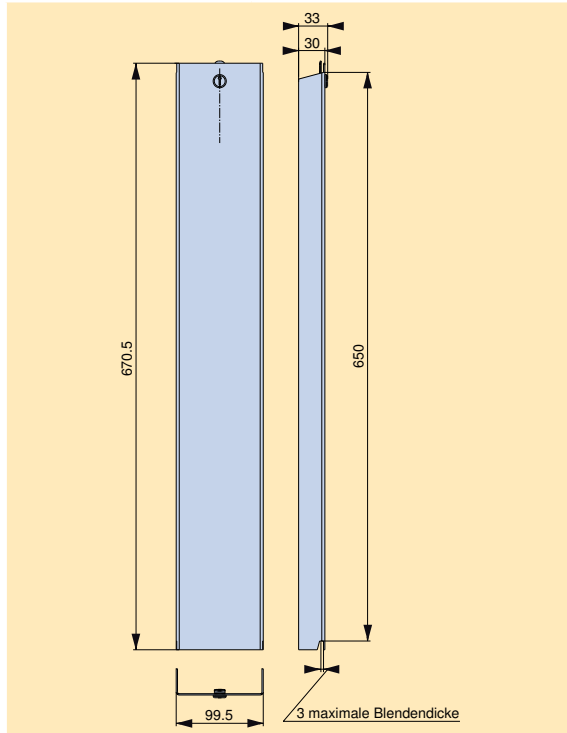

NH-Sicherungs-
leisten
*NH strip-
fuseways*

**NH-Sicherungs-
lastschaltleisten**
*NH strip-
type fuse-switch-
disconnectors*

NH-Sicherungs-
lasttrennschalter
*NH fuseswitch-
disconnectors*

C|O|S|I|M|O®
C|O|S|I|M|O®

Klemmen
Terminals

Anhang
Appendix

NH-Sicherungslastschaltleisten

NH strip-type fuse-switch-disconnectors

Typ/Type	Artikel-Nr./Article-No.	Seite/Page
H-RF	S8900954	SL-35

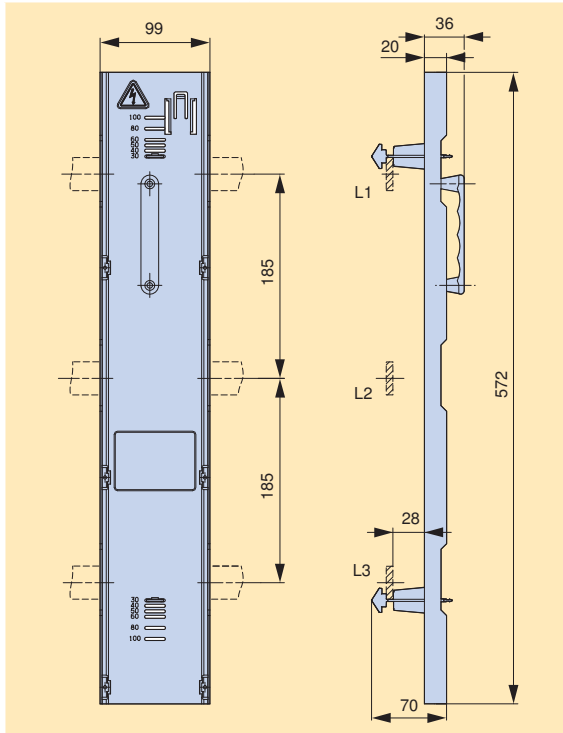

Typ/Type	Artikel-Nr./Article-No.	Seite/Page
H-SL00	L8550068	SL-34

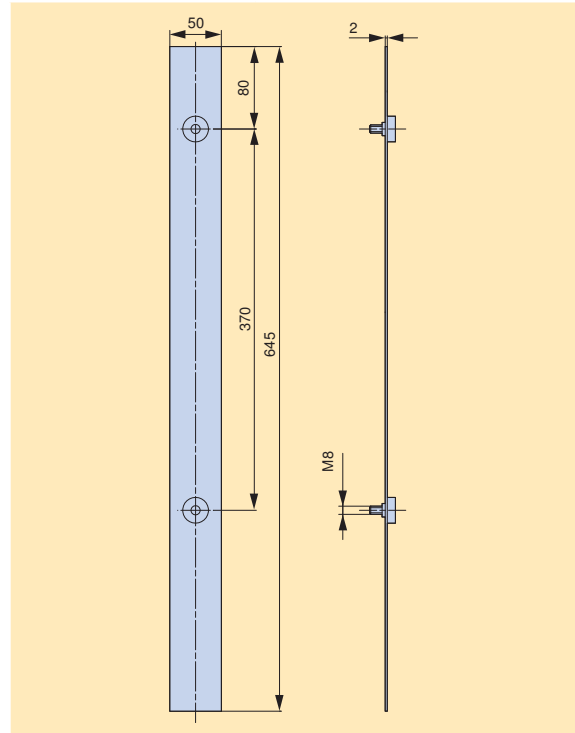

Typ/Type	Artikel-Nr./Article-No.	Seite/Page
H-SL00/100	L8520323	SL-34

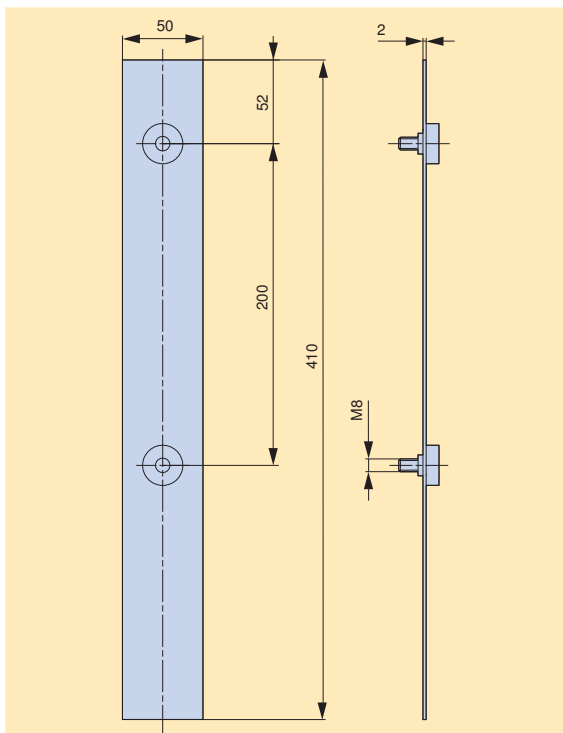

Typ/Type	Artikel-Nr./Article-No.	Seite/Page
H-SL123/662	L8220083	SL-34

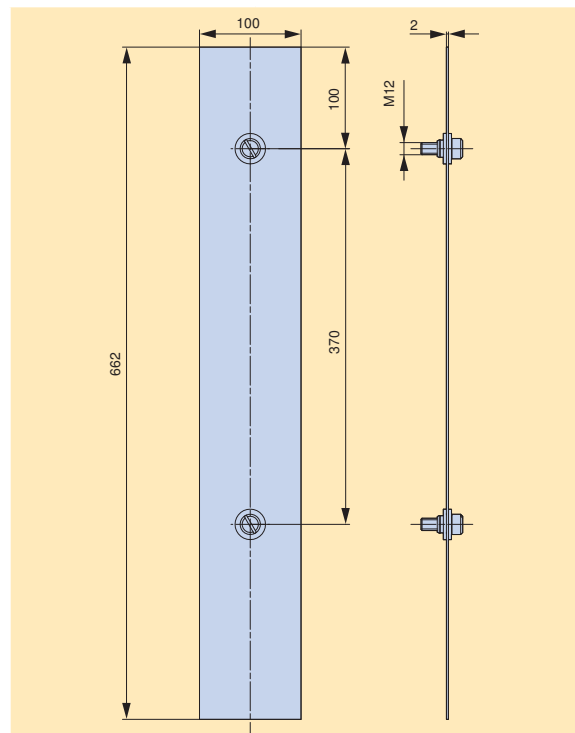

Typ/Type	Artikel-Nr./Article-No.	Seite/Page
H-SL123/ST	L8220166	SL-34

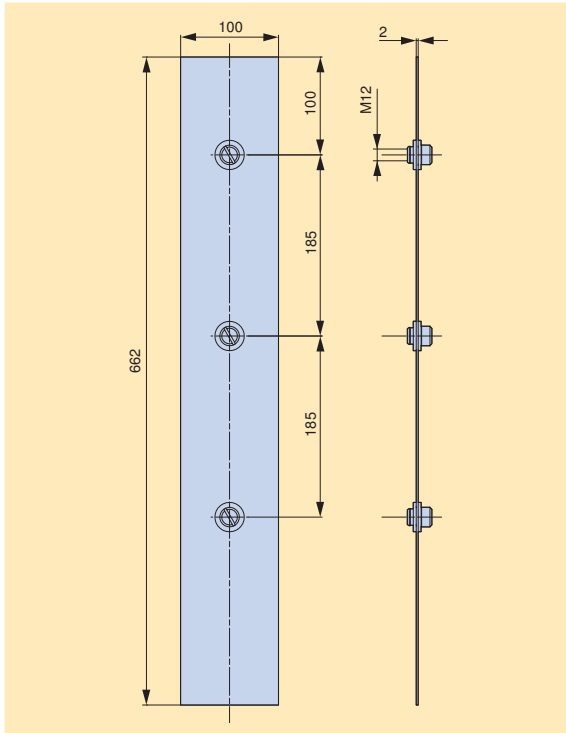

Typ/Type	Artikel-Nr./Article-No.	Seite/Page
LA-SL00	L8520350	SL-35

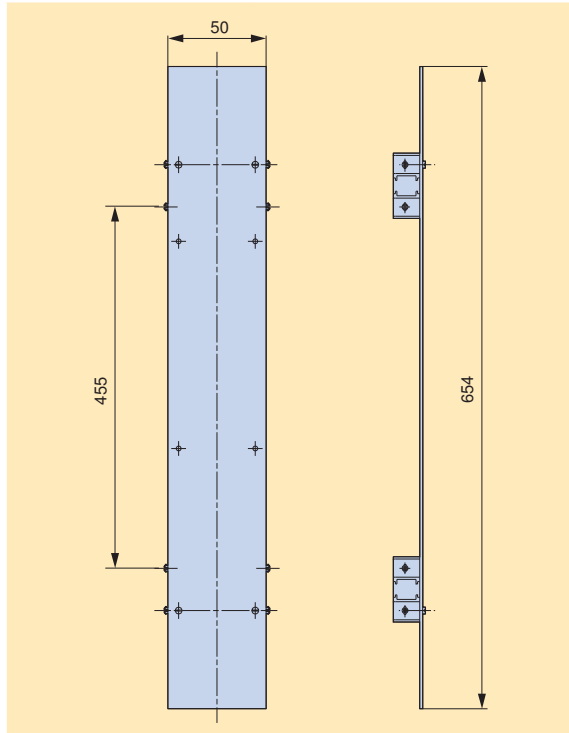

Typ/Type	Artikel-Nr./Article-No.	Seite/Page
LA-SL123	L8920351	SL-35

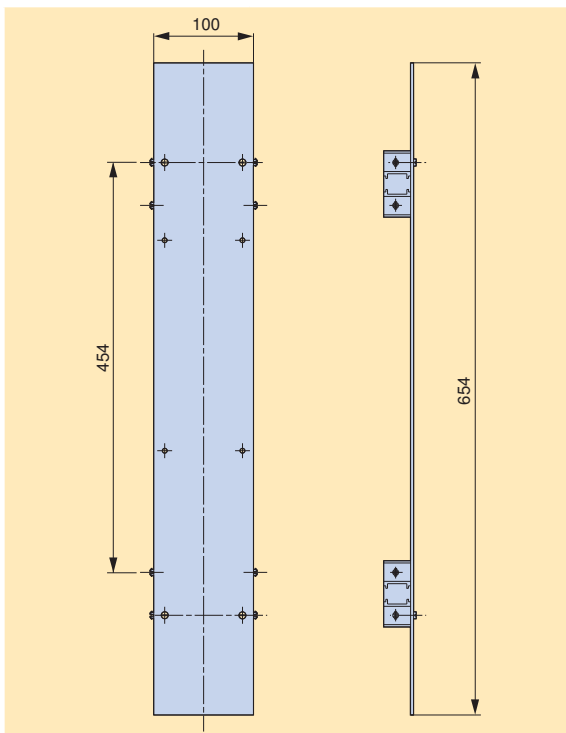

Typ/Type	Artikel-Nr./Article-No.	Seite/Page
AH-SL	L8290020	SL-35

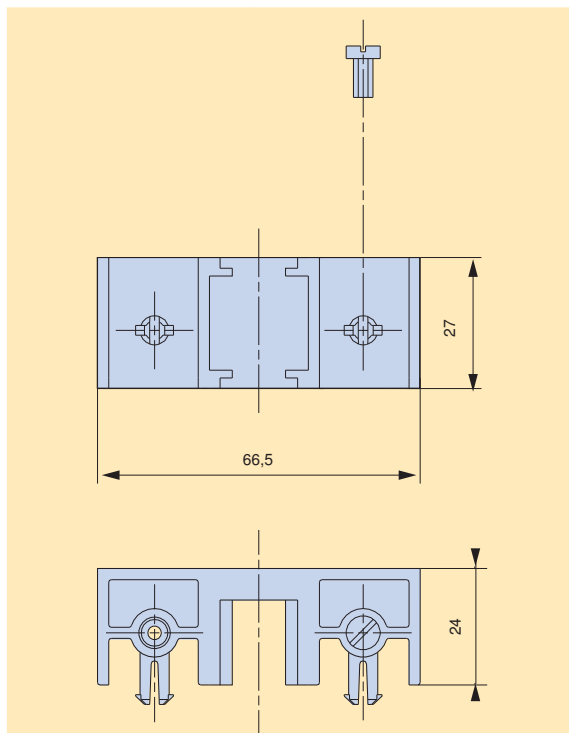

NH-Sicherungs-
leisten
*NH strip-
fuseways*

NH-Sicherungs-
lastschaltleisten
*NH strip-
fuse-switch-
disconnectors*

NH-Sicherungs-
lasttrennschalter
*NH fuseswitch-
disconnectors*

C|O|S|I|M|O®
CIOISIMIO®

Klemmen
Terminals

Anhang
Appendix

NH-Sicherungslastschaltleisten

NH strip-type fuse-switch-disconnectors

Typ/Type	Artikel-Nr./Article-No.	Seite/Page
AH-SL/S	L8290106	SL-35

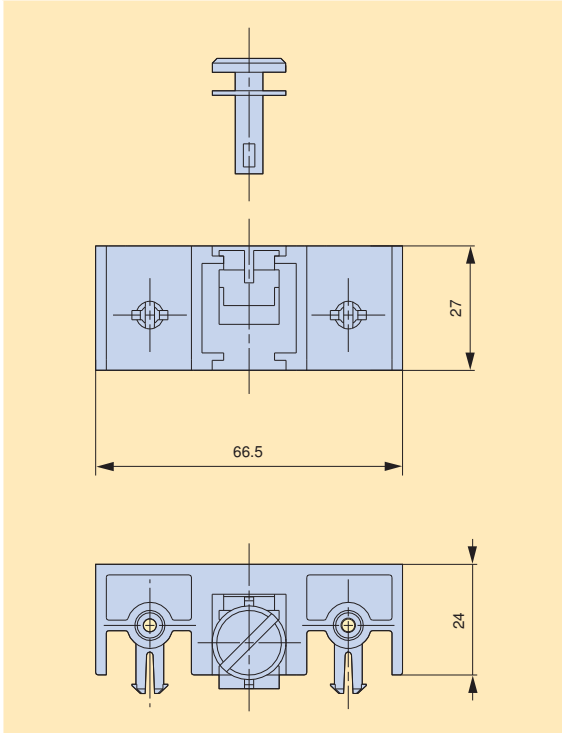

Typ/Type	Artikel-Nr./Article-No.	Seite/Page
AHCT-SL00-3	L8990272	SL-35

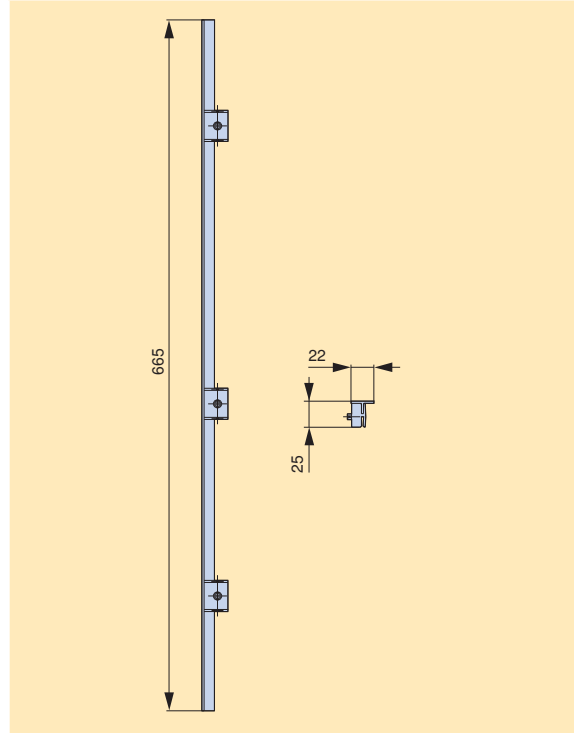

Typ/Type	Artikel-Nr./Article-No.	Seite/Page
HU-SLTL4A	L8420197	SL-35

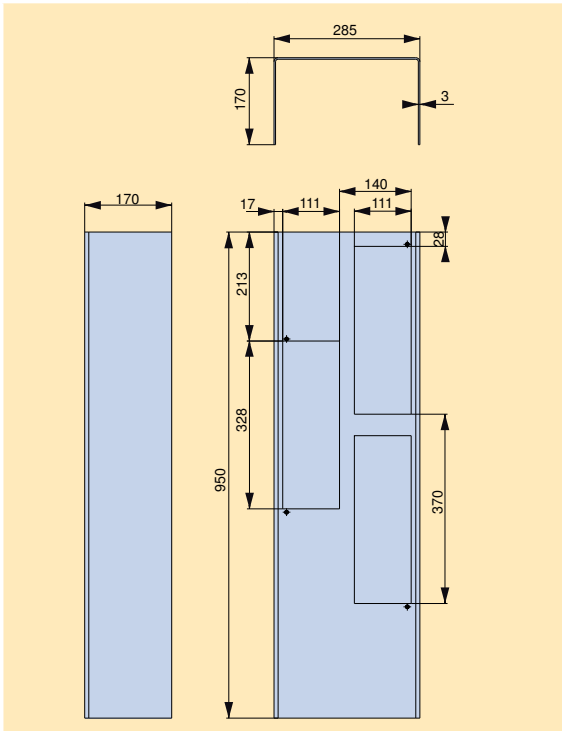

Typ/Type	Artikel-Nr./Article-No.	Seite/Page
HF-SLTL4A	L8420210	SL-35

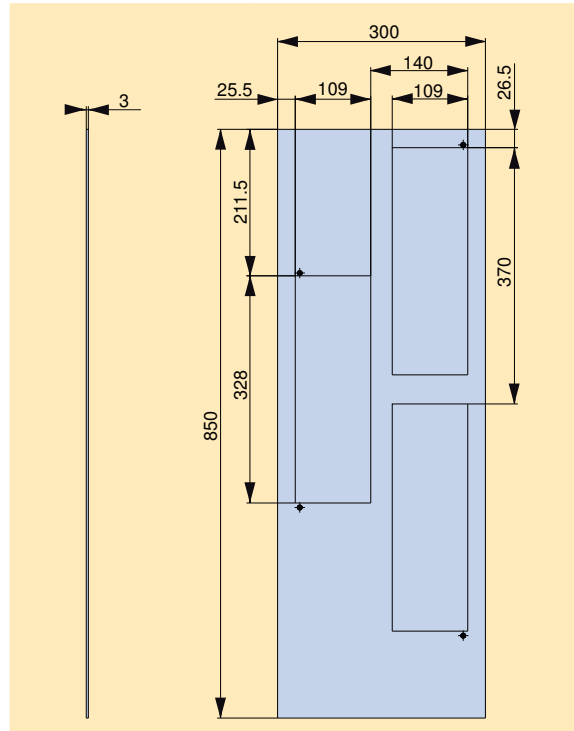

Typ/Type	Artikel-Nr./Article-No.	Seite/Page
BZO-SL00	L8590656	SL-35

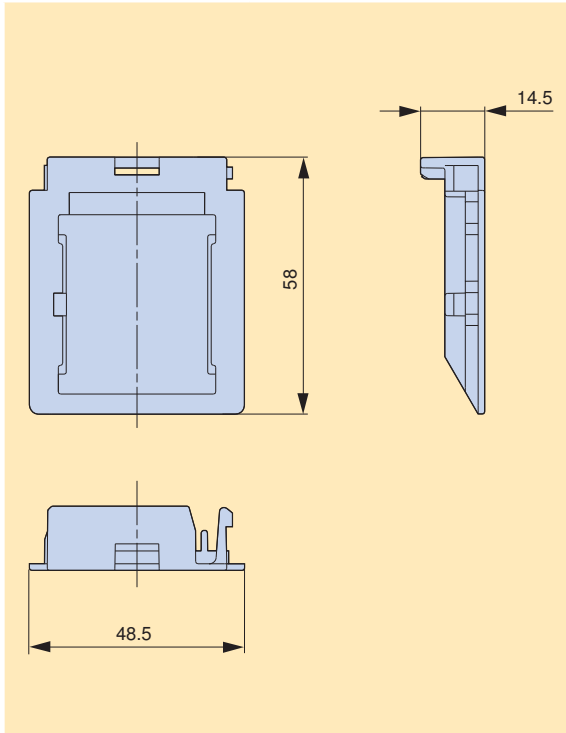

Typ/Type	Artikel-Nr./Article-No.	Seite/Page
BZO-SL123/10	L8990251	SL-35

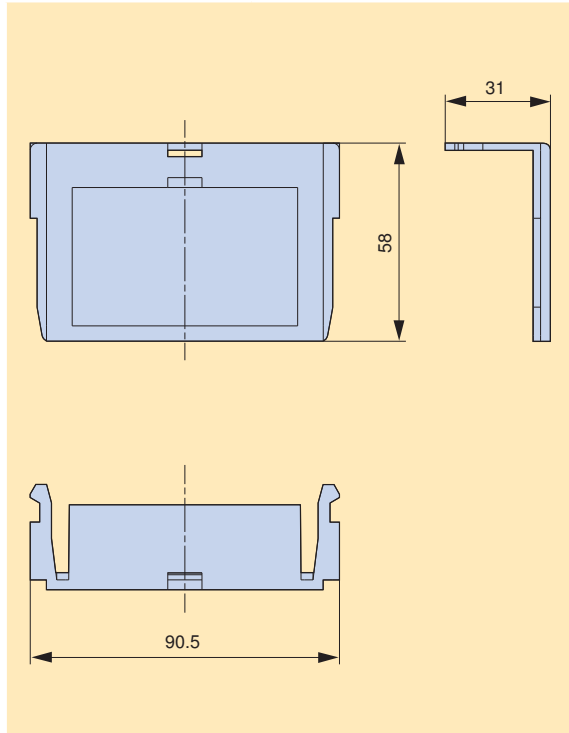

Typ/Type	Artikel-Nr./Article-No.	Seite/Page
10W/L3-L/SL123	L8990658	SL-36

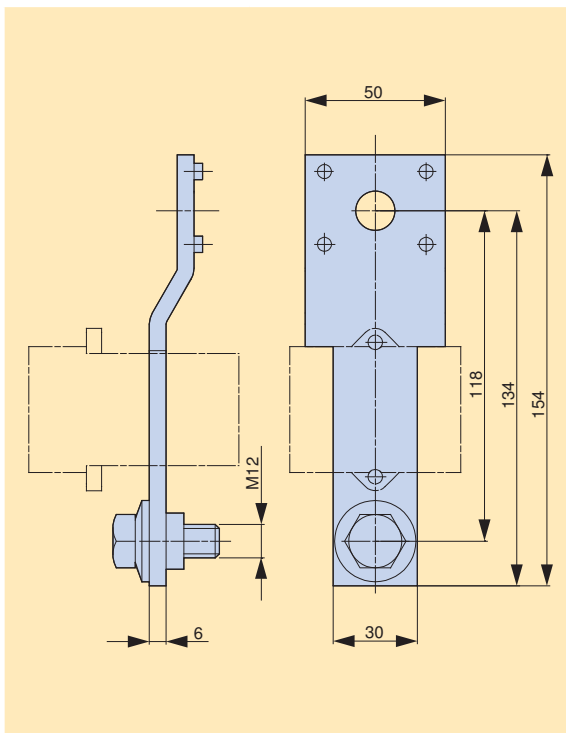

NH-Sicherungs-
leisten
*NH strip-
fuseways*

NH-Sicherungs-
lastschaltleisten
*NH strip-
type fuse-switch-
disconnectors*

NH-Sicherungs-
lasttrennschalter
*NH fuseswitch-
disconnectors*

C|O|S|I|M|O®
C|O|S|I|M|O®

Klemmen
Terminals

Anhang
Appendix

NH-Sicherungslastschaltleisten

NH strip-type fuse-switch-disconnectors

Typ/Type	Artikel-Nr./Article-No.	Seite/Page
30W-L/SL123	L8900652	SL-36

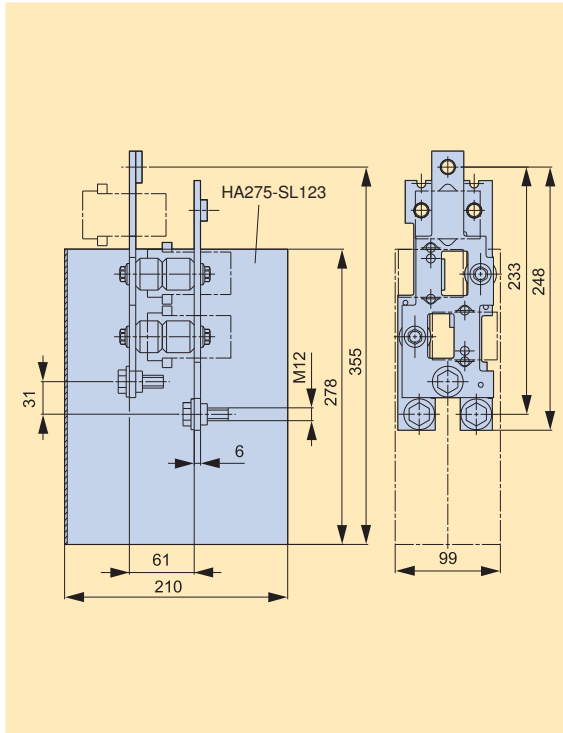

Typ/Type	Artikel-Nr./Article-No.	Seite/Page
SH100/185	S8900003	SL-36

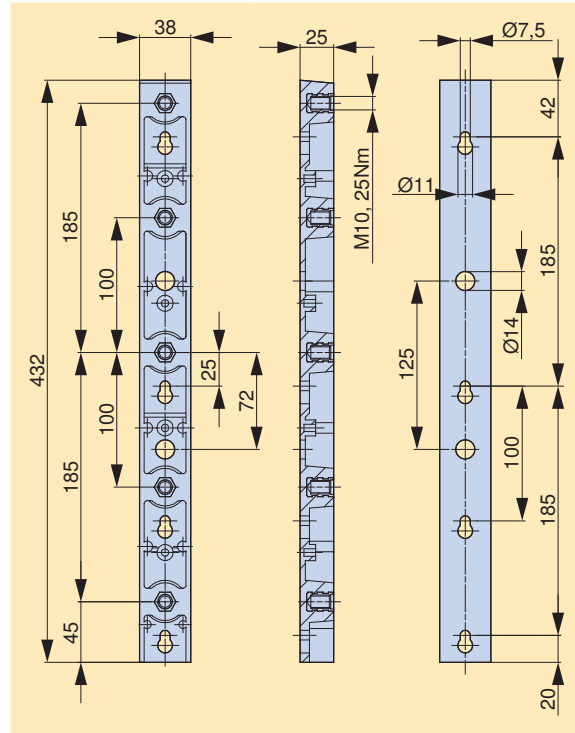

Typ/Type	Artikel-Nr./Article-No.	Seite/Page
HP-SE/L	L8990491	SL-36

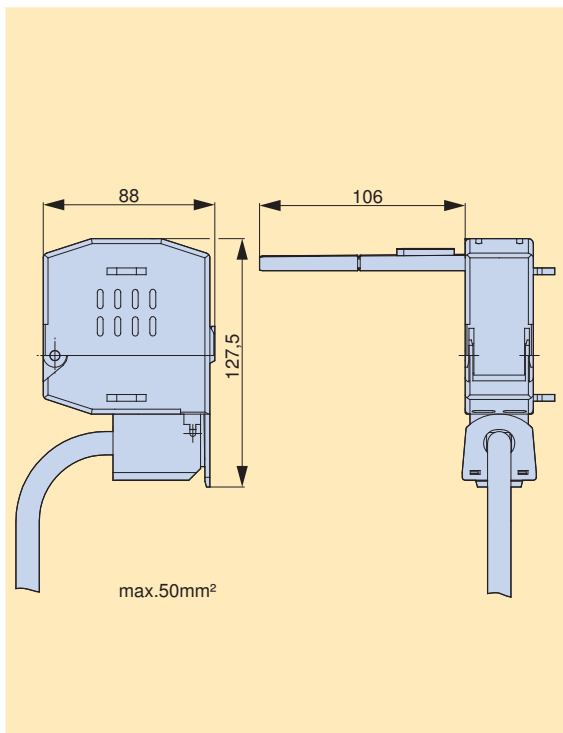

Typ/Type	Artikel-Nr./Article-No.	Seite/Page
SK-S0070	K5441020	SL-36

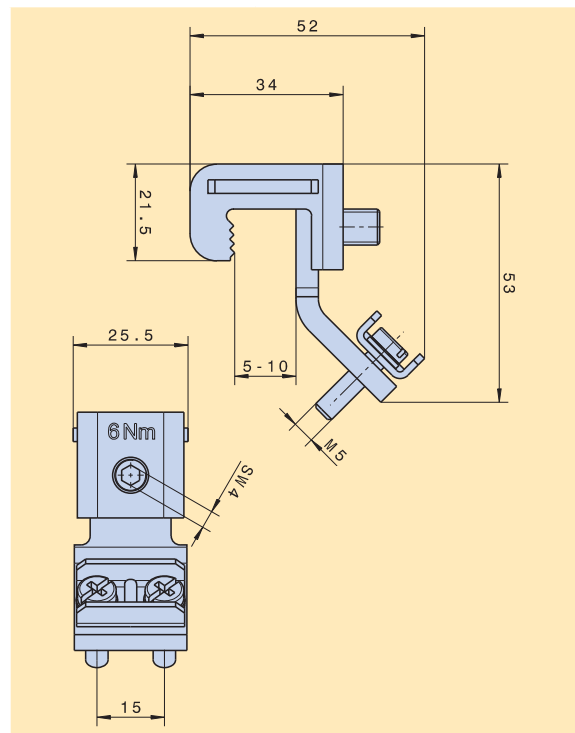

Typ/Type	Artikel-Nr./Article-No.	Seite/Page
VS-SL3/1000	L8390600	SL-36

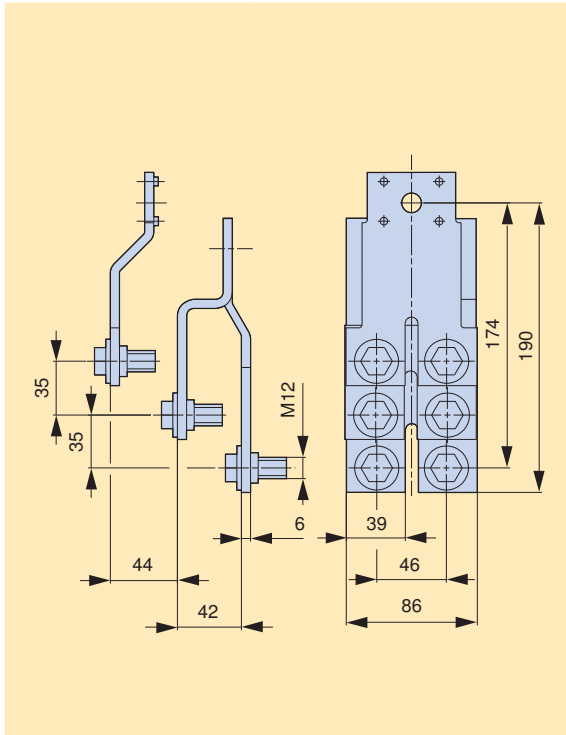

Typ/Type	Artikel-Nr./Article-No.	Seite/Page
FK2x240-SL23	L8290160	SL-32

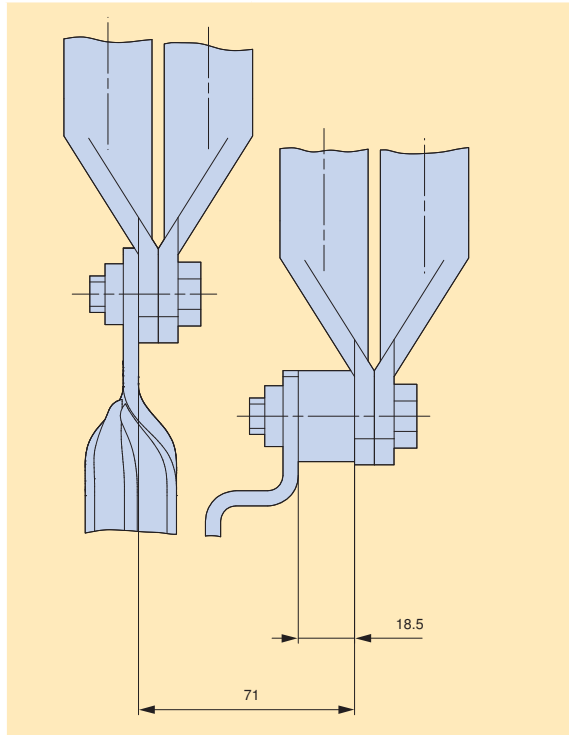

Typ/Type	Artikel-Nr./Article-No.	Seite/Page
SK-L/SL00	L8570207	SL-33

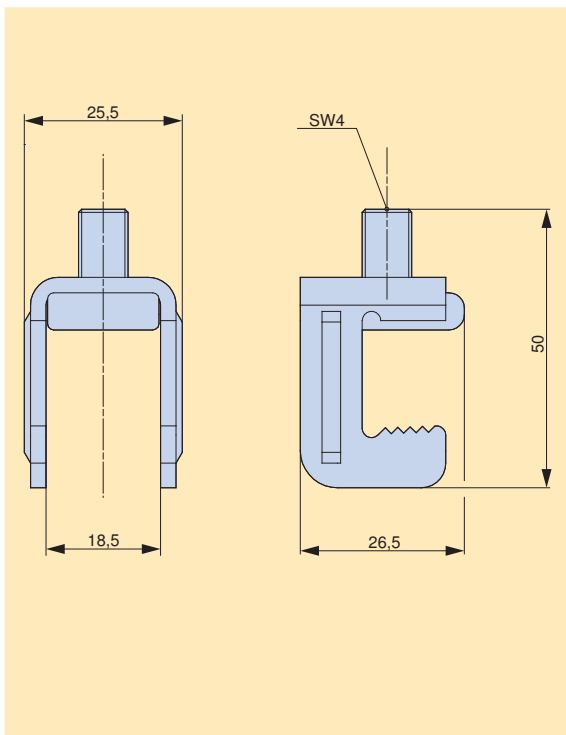

Typ/Type	Artikel-Nr./Article-No.	Seite/Page
VS-SL3/400QMM	L8390937	SL-36

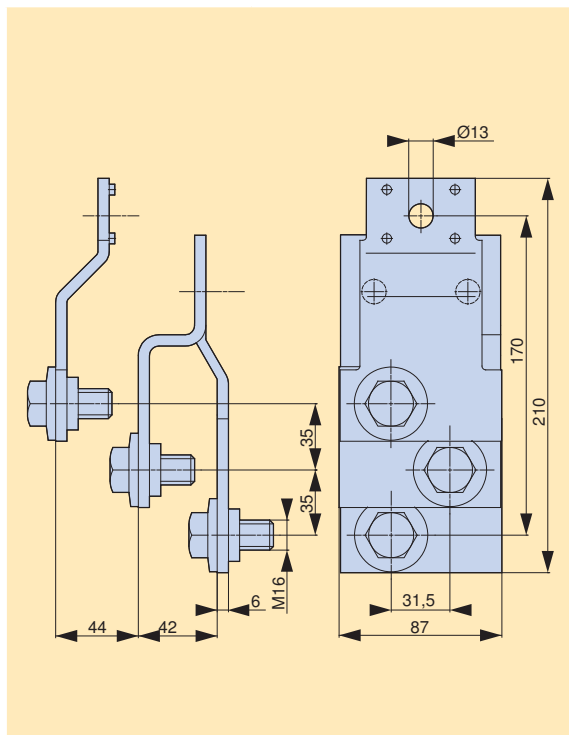

NH-Sicherungs-
leisten
*NH strip-
fuseways*

NH-Sicherungs-
lastschaltleisten
*NH strip-
type fuse-switch-
disconnectors*

NH-Sicherungs-
lasttrennschalter
*NH fuseswitch-
disconnectors*

C|O|S|I|M|O®
C|O|S|I|M|O®

Klemmen
Terminals

Anhang
Appendix

NH-Sicherungslastschaltleisten

NH strip-type fuse-switch-disconnectors

Typ/Type	Artikel-Nr./Article-No.	Seite/Page
VBS-SL3X2(6)	L8990668	SL-36

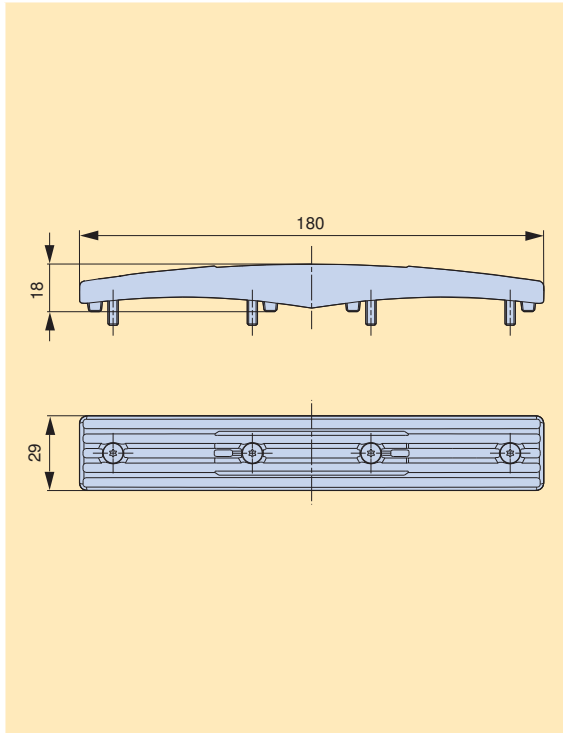

Typ/Type	Artikel-Nr./Article-No.	Seite/Page
VS-SL123/4x240QMM	L8390921	SL-36

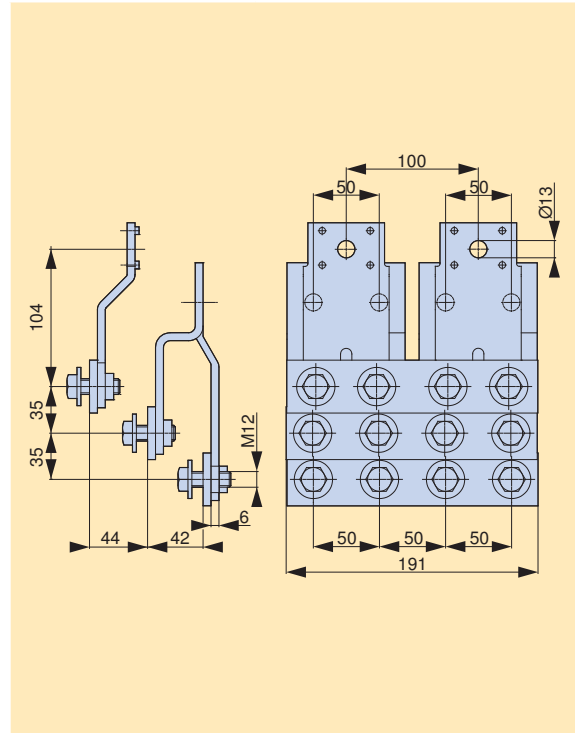

Typ/Type	Artikel-Nr./Article-No.	Seite/Page
VS-SL3/1250	L8990669	SL-36

